



Installation & Operations Manual

IMPORTANT FOR FUTURE REFERENCE

Please complete this information and retain this manual for the life of the equipment:

Model #: _____

Serial #: _____

Date Purchased: _____

Oven Range

Model RH36, MH36

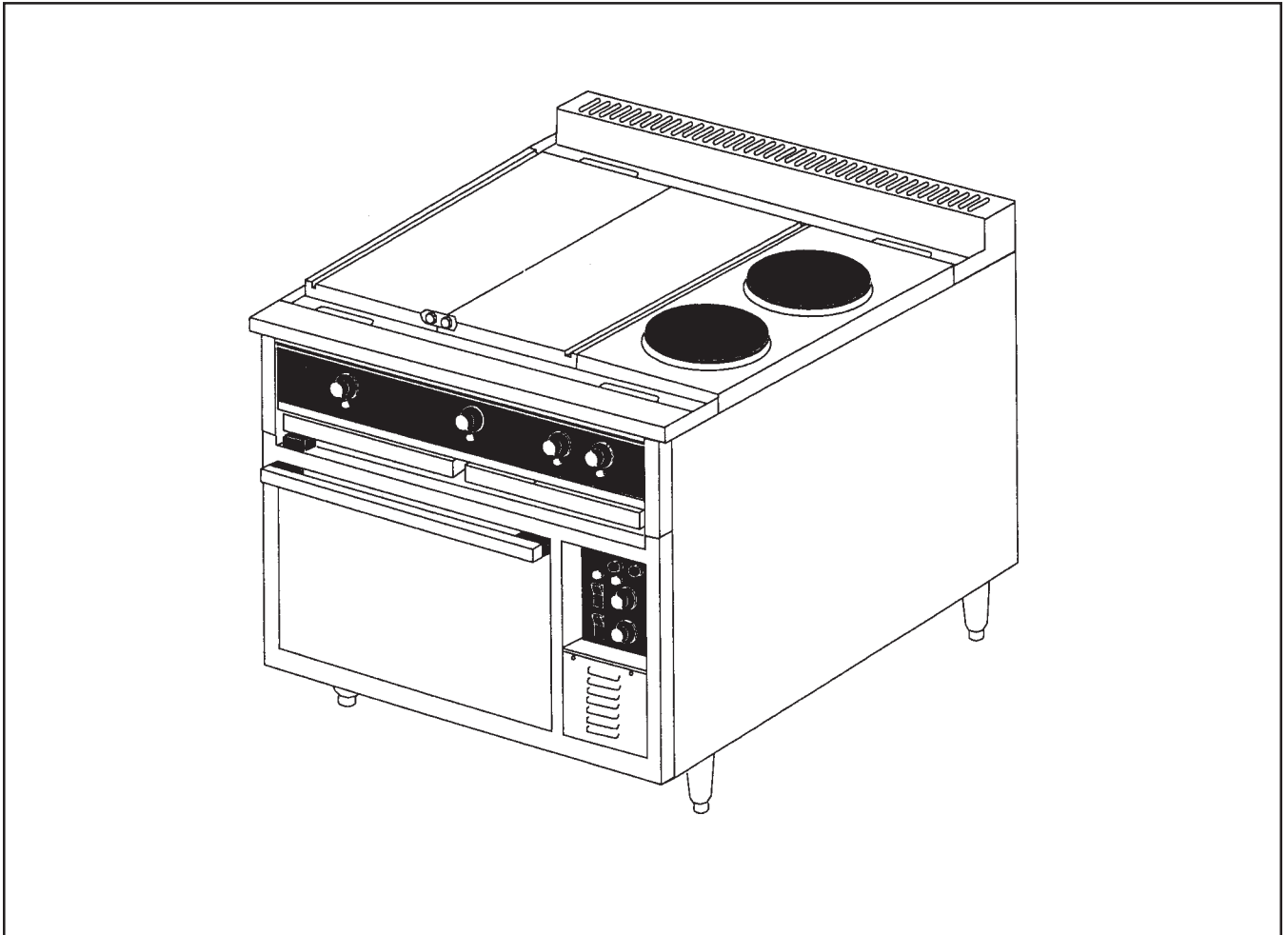

WARNING

FOR YOUR SAFETY, DO NOT STORE OR USE GASOLINE OR OTHER FLAMMABLE VAPORS AND LIQUIDS IN THE VICINITY OF THIS OR ANY OTHER APPLIANCE.

WARNING

In case of fire, de-energize the Oven Range at its main disconnect switch/circuit breaker. Switching OFF the power to the Oven Range allows it to cool, making it easier to extinguish a fire.

WARNING

ONLY use a CO₂ or other fire extinguisher suitable for grease, oil, and electrical equipment fires. Do NOT try to stop a grease fire by pointing the fire extinguisher nozzle directly on the burning grease. Direct the nozzle to the outside of the flames to prevent them from spreading. Gradually, spray closer to the center of the flames, to cool and smother them.

CAUTION

DO NOT move the Oven Range while cooking. Pots of liquid could spill, causing injury.

NOTICE

Contact your local authorized Service Agency to perform maintenance and repairs. A Service Agency directory is supplied with your oven.

NOTICE

Using any parts other than genuine Toastmaster factory-supplied parts relieves the manufacturer of all liability.

NOTICE

Toastmaster (Manufacturer) reserves the right to change specifications and product design without notice. Such revisions do not entitle the buyer to corresponding changes, improvements, additions or replacements for previously purchased equipment.



PROBLEMS, QUESTIONS or CONCERNS

Before you proceed consult you authorized Toastmaster service agent directory
or
Call the Technical Service & Parts Department at 1-800-807-9054.

Table of Contents

SECTION 1	
DESCRIPTION	1
A. Oven Base	1
B. Range.	2
C. Specifications.	7
SECTION 2	
INSTALLATION	9
A. Inspection For Shipping Damage	9
B. Installation of Oven Range	10
C. Assembling of Oven Range.	11
D. Electrical Connection.	11
E. Initially Cleaning the Griddle and/or Hot Plates.	11
F. Testing the Installation.	12
G. Marine Oven Range Installation On Curb	12
H. Dimension Drawings	13-14
SECTION 3	
OPERATION	15
I. Component Function and Location	15
II. Control Functions and Location.	16
III. Operation.	19
IV. Time and Temperature Charts.	24
SECTION 4	
PARTS LIST	29
Overall Drawing Parts List	30
Convection Oven	34
Deck Oven	36
Vents and Marine Rails.	38
SECTION 5	
SCHEMATICS	40
Electrical Schematics & Wiring.	41-83

This page intentionally left blank

SECTION 1 DESCRIPTION

I. Description

Toastmaster Model RH36 and MH36 electric oven ranges are rated heavy duty for commercial use. The oven range consists of a range top fastened to an oven base. There is a marine kit available which qualify it for shipboard use. The marine features are an oven door latch, grease tray latch, bolt-down legs , range top adjustable sea rails and a grab bar across the front.

A. OVEN BASE

the oven base can be either a deck oven or convection oven.

1. Deck Oven ("D" in Model #, example RH36D1)

The deck oven base has an aluminized steel inner lining, removable deck of rigidized steel, vent with damper and fully gasketed landing shelf type stainless steel lined door. The oven is insulated on all sides and is equipped with one slide-in rack. Heating is accomplished with top and bottom formed tubular heating elements which are each controlled by a 3-heat (low, medium, high) switch. The deck oven has a thermostatic control with a temperature range of 200°F to 550°F (93°C to 287°C). The oven will preheat to 450°F (232°C) in 20 minutes.

2. Convection Oven ("A" in Model #, example RH36C1)

The convection oven has removable stainless steel oven liners, vent damper and fully gasketed landing shelf type stainless steel lined door. The oven is insulated on all sides. Removable rack supports can accommodate six racks. The heating element is enclosed in the side of the oven cavity and encircles the oven blower fan. The convection oven has a thermostatic control with a temperature range of 150°F to 450°F (65°C to 232°C). The oven will preheat to 450°F (232°C) in 15 minutes.

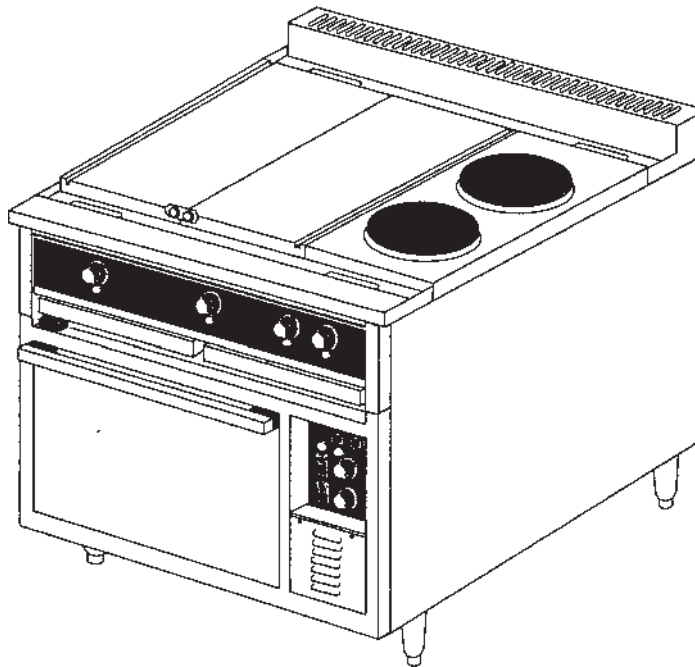

Figure 1-1

Section 1 - Description

B. RANGE

The range can consist of up to 3 different components and the components can be configured in six ways. Troughs with drip chutes are located at the front and rear for draining into two wide drawer type receptacles

1. Range Components Descriptions

a. **Griddle** for griddling. The griddle can be either 24"x24" or 24" x 36". The griddles are controlled by thermostats. The 24"x24" griddle has a thermostat control for each of two 12"x24" zones and the 24"x 36" griddle has a thermostat for each of four 9"x24" zones. The griddle zones have a temperature range of 150°F to 450°F (65°C to 232°C) and will preheat to 400°F (204°C) in 12 minutes.

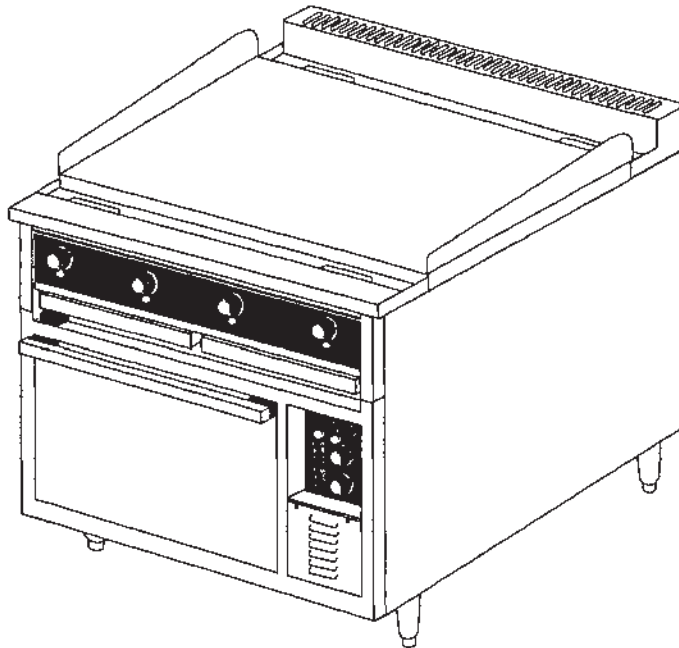

Figure 1-2
Griddle

Section 1 - Description

b. 12"x24" Hot Plate for stock pot cooking (Not recommended for griddling). The hot plates are thermostatically controlled and have a temperature range of 250°F to 850°F (121°C to 454°C) and will preheat to 400°F (204°C) in 12 minutes

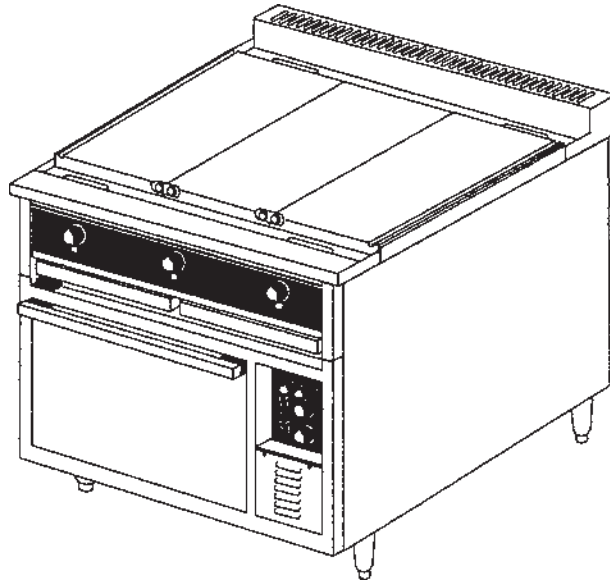

Figure 1-3
Hot Plate

c. Round Hot Plate for stock pot cooking. The twin hot plates have a 9" diameter and are controlled by 3-heat (low, medium, high) switches.

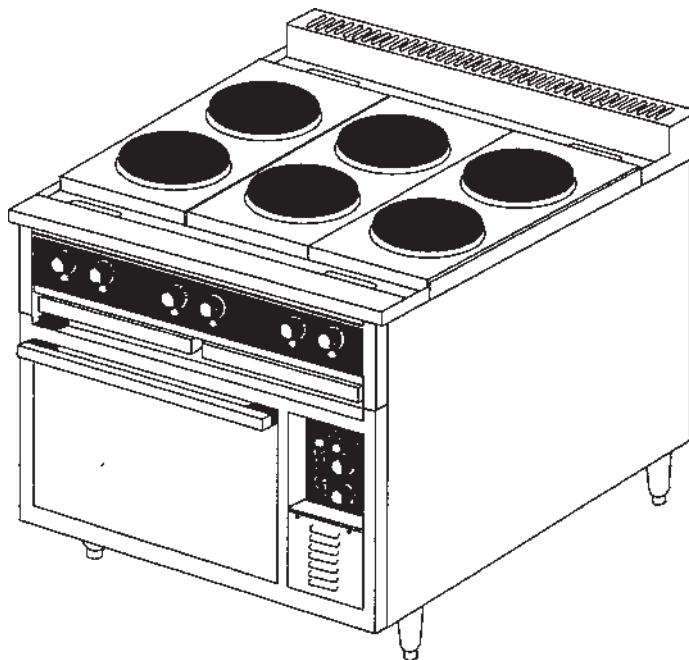
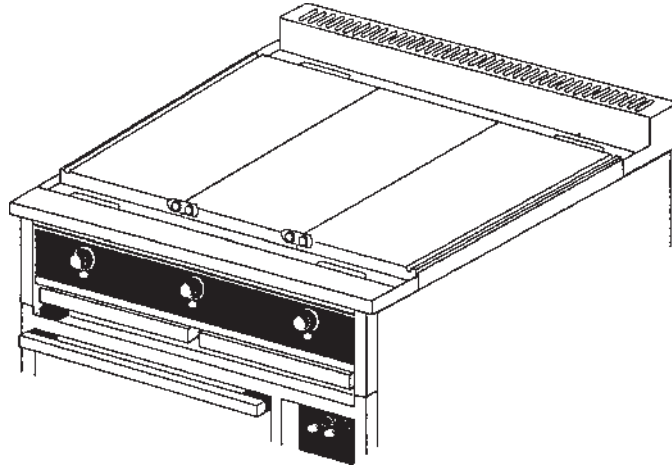

Figure 1-4
Round Hot Plate

Section 1 - Description

2. Range Top Configurations

a. **All purpose TOP RH36C1, RH36D1.** The all purpose top consists of three 12"x 24" hot plates. The all purpose top is not recommended for griddling



**Figure 1-5
All Purpose Plate**

b. **Multi-Purpose Top RH36C2, RH36D2** The multi purpose top consists of two 12"x 24" hot plates and two 9" round hot plates. The multipurpose top is not recommended for griddling.

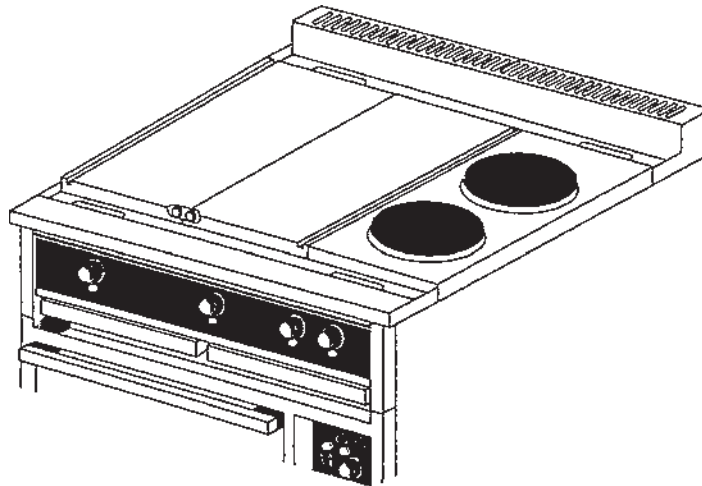

**Figure 1-6
Multi-Purpose Top**

c. **Griddling Top RH36C3, RH36D3.** the griddle top consists of one 36"x24" griddle plate.

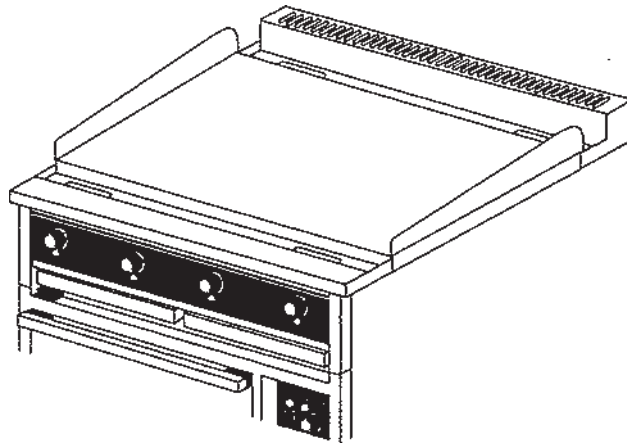

Figure 1-7
Griddle Top

d. **Round Hot Plate Top RH36C4, RH36D4.** The round hot plate top consists of six 9" hot plates.

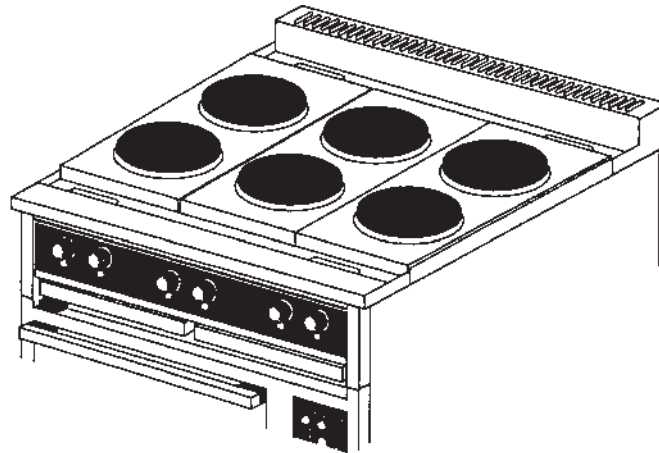

Figure 1-8
Round Hot Plate

Section 1 - Description

e. **Griddle/Round Hot Plate Top RH36C6, RH36D6.** The griddle/round hot plate top consists of one 24"x24" griddle and two 9" round hot plates.

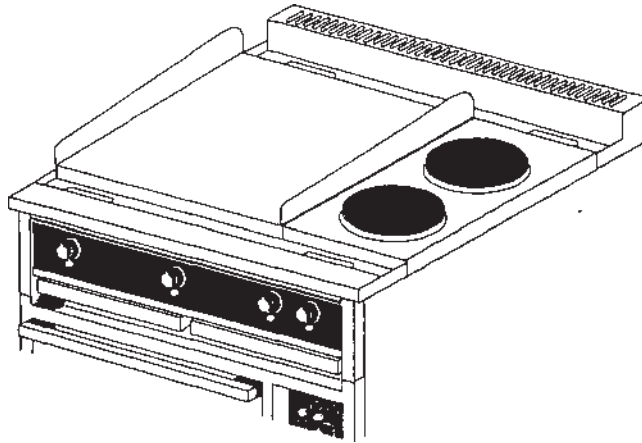

Figure 1-9
Griddle/Round Hot Plate

f. **Griddle 12"x24" Hot Plate Top RH36C7, RH36D7.** The griddle 12" x 24" hot plate top consists of one 24" x 24" griddle and one 12"x24" hot plate.

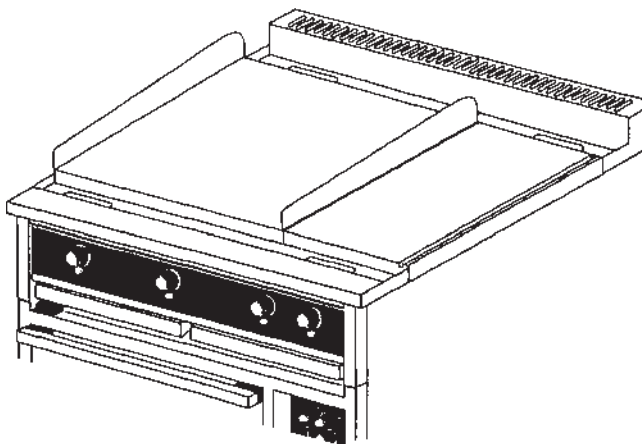

Figure 1-10
Griddle/Hot Plate

C. Specifications

OVEN RANGE MODELS	SE36
Overall Dimensions	
Width	36" (91.5cm)
Depth	38-3/4" (96.4cm)
Height	38-1/4" (97cm)
Net Weight	
Model RH36C1 & MH36C1	569 lb (258 kg)
Model RH36C2 & MH36C2	515 lb (234 kg)
Model RH36C3 & MH36C3	588 lb(267 kg)
Model RH36C4 & MH36C4	455 lb (207 kg)
Model RH36C6 & MH36C6	515 lb (234 kg)
Model RH36C7 & MH36C7	545 lb (247 kg)
Model RH36D1 & MH36D1	569 lb (258 kg)
Model RH36D2 & MH36D2	515 lb (234 kg)
Model RH36D3 & MH36D3	588 lb (267 kg)
Model RH36D4 & MH36D4	497 lb (226 kg)
Model RH36D6 & MH36D6	515 lb (234 kg)
Model RH36D7 & MH36D7	545 lb (247 kg)
Shipping Weight	
Model RH36C1 & MH36C1	610 lb (227 kg)
Model RH36C2 & MH36C2	570 lb (259 kg)
Model RH36C3 & MH36C3	610 lb(277 kg)
Model RH36C4 & MH36C4	485 lb (220 kg)
Model RH36C6 & MH36C6	570 lb (259 kg)
Model RH36C7 & MH36C7	545 lb (247 kg)
Model RH36D1 & MH36D1	569 lb (258 kg)
Model RH36D2 & MH36D2	515 lb (234 kg)
Model RH36D3 & MH36D3	588 lb (267 kg)
Model RH36D4 & MH36D4	497 lb (226 kg)
Model RH36D6 & MH36D6	515 lb (234 kg)
Model RH36D7 & MH36D7	545 lb (247 kg)
Construction	----- Welded Angle Iron -----
Finish:	----- Stainless Steel Front Sides and Top ----- ----- Aluminized Steel Back -----
Electrical Specifications	Refer to Section 5

NOTICE

Toastermaster (Manufacturer) reserves the right to change specifications and product design without notice. Such revisions do not entitle the buyer to corresponding changes, improvements, additions or replacements for previously purchased equipment.



Section 1 - Description

NOTES

SECTION 2 INSTALLATION

A. Inspect for Shipping Damage

All shipping containers should be examined for damage before and during unloading. This equipment was carefully inspected and packaged at the factory. The freight carrier has assumed responsibility for its safe transit and delivery. If equipment is received in damaged condition, either apparent or concealed, a claim must be made with the delivering carrier.

1. Apparent Damage or Loss - If damage or loss is apparent it must be noted on the freight bill or express receipt at the time of delivery, and must be signed by the carrier's agent (driver). If this is not done, the carrier may refuse the claim. The carrier will supply the necessary claim forms.

2. Concealed Damage or Loss - If damage or loss is NOT apparent until after equipment is unpacked, a request for inspection of concealed damage must be made with the carrier within 15 days. The carrier will make an inspection and will supply necessary claim forms. Be certain to retain all contents plus external and internal packaging materials for inspection.

Section 2 - INSTALLATION

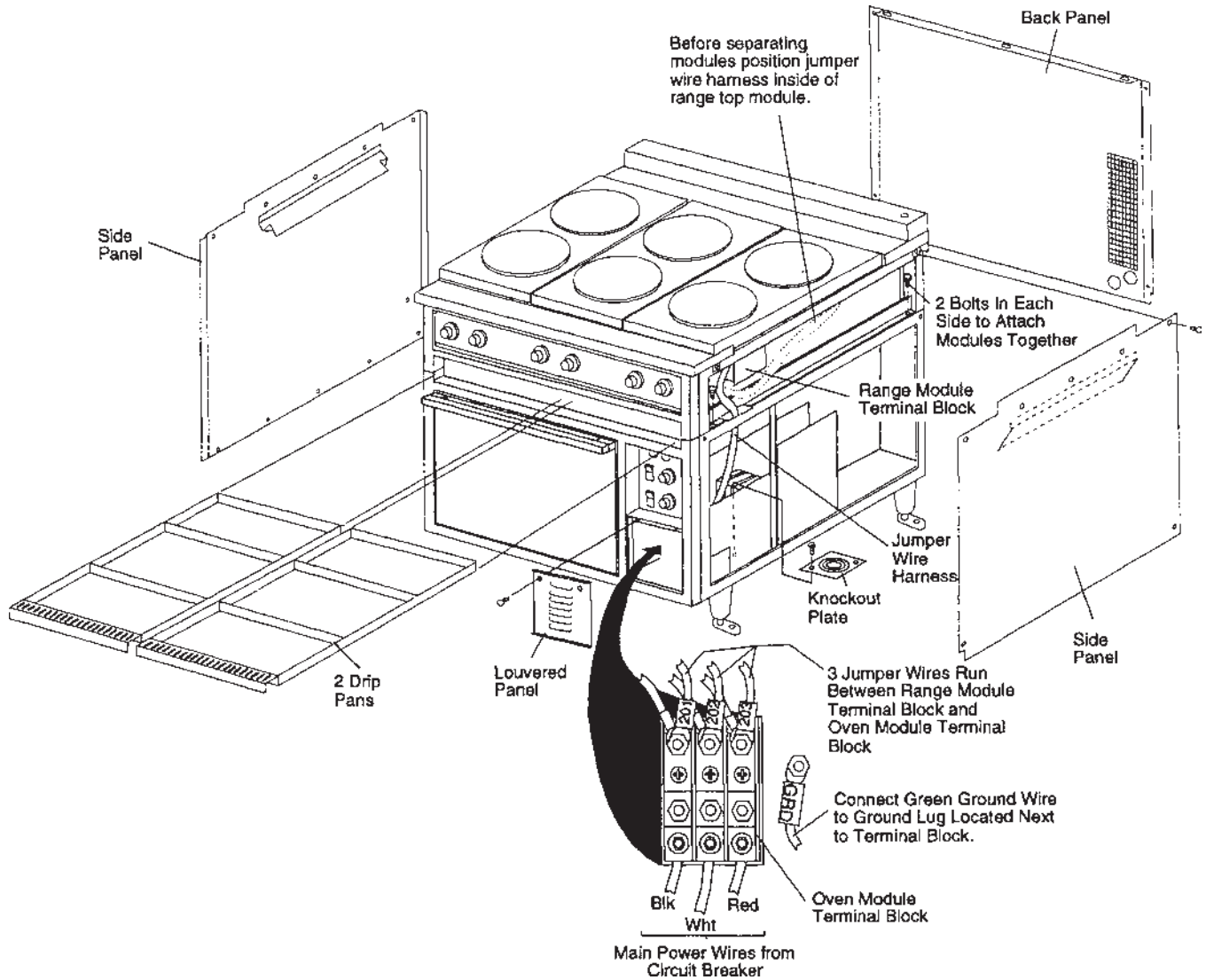

Figure 2-1

B. Inspect of Oven Range

The oven range can be shipped assembled or the range top module and the oven can be packed in separate cartons. If the oven range is shipped assembled simply remove the metal banding straps and packing materials and move it to the permanent location.

If the oven range is packed in two separate cartons and must be moved through a narrow passage follow the Pre-Installation instructions located on the outside of the carton. If the oven range does not have to be moved through a narrow doorway then simply remove the metal banding straps and packing materials and move each carton to the permanent location. Use the following procedure to assemble the range top and oven modules.

C. Assembling (Stacking) the Oven Module and Range Module

1. Move the range top module and the oven module to the area of their permanent location as directed in the previous Paragraph "B" or the Pre-installation Instructions on the outside of the shipping carton.
2. Remove the following (refer to Figure 2-1):
 - Two drip pans
 - Two side panels
 - Back cover
 - Front louvered panel located below control panel
3. Place range top module in position on oven module.
4. Attach range top to oven using two 5/16" hex bolts on each side of the oven (4 bolts total, furnished). Refer to Figure 2-1
5. Thread jumper wire harness from range top through oven base frame opening and connect wires marked 201, 202 and 203 to terminal block as shown in Figure 2-1.
6. Remove all remaining packing materials.
7. On Marine Oven Ranges bolt the oven range to the floor/deck using the leg brackets.

D. Electrical Connection

1. Remove the right side panel and the front louvered panel located below the control panel if they have not already been removed.
2. Remove knockout plate located below terminal block on oven floor as shown in Figure 2-1. Knockout desired hole in knockout plate. Reassembled knockout plate to floor of oven.
3. Connect main power wires from circuit breaker to terminal block as shown in Figure 2-1.
4. Reinstall all panels and drip pans that were removed.

E. Initially Clean the Griddle and/or 12" x 24" Hot Plate(s)

1. Remove the rust preventative material from the surface with a nonflammable grease solvent.
2. Wash the surface with warm water and a mild detergent.
3. Rinse with a damp cloth and wipe dry.
4. Griddle must then be seasoned immediately. Refer to Section 3, Operation, for procedure to follow.

Section 2 - INSTALLATION

F. Testing the Installation

1. Turn all range and oven controls to the OFF position.
2. Turn main power disconnect switch to ON
3. Check range top components by turning on one control at a time starting at the left side of the control panel. Check that the component is starting to heat and then turn it off.
4. Check the oven controls.
 - a. Deck oven - Set thermostat control at 300°F (149°C). turn both the upper and lower heating element switches to LOW. Check that both the upper and lower elements are starting to heat and then turn them to OFF.
 - b. Convection oven - Set thermostat control to 300°F(149°C). Push fan switch LOW position. Turn oven power switch ON. After a few minutes open oven door and check for heat. If oven is heating turn all controls to OFF

G. Marine Oven Range Installation on Curb

1. Installation of Oven Range on metal curb (shipped separately)
 - a. Bolt or weld base flange of metal curb (P/N33669) to floor of ship. See figure 2-2.
 - b. Position oven range on curb as shown in figure 2-3.
 - c. Remove oven side covers and use existing mounting holes to bolt oven range to top flange of curb.
2. Installation of Oven Range on existing curb.
 - a. Existing curb must be ventilated as shown on metal curb in Figure 2-3. The opening for circulation must equal 8 square ft. (0.74 square meters).
 - b. Remove oven side covers and use existing mounting holes to bolt oven range to top of curb.

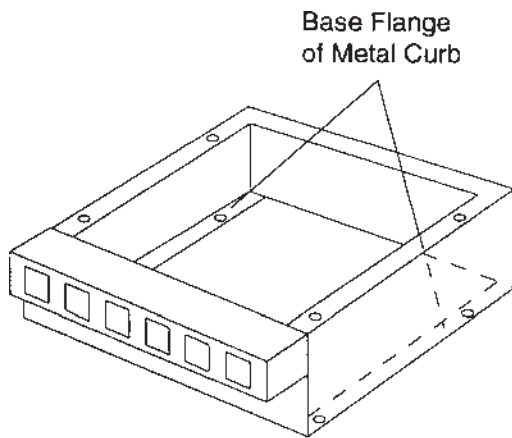

Fig. 2-2
Metal curb

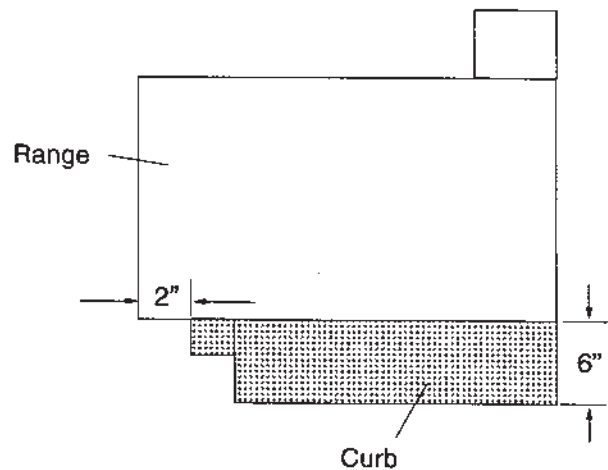

Fig. 2-3
Oven range on curb

H. Dimension Drawings

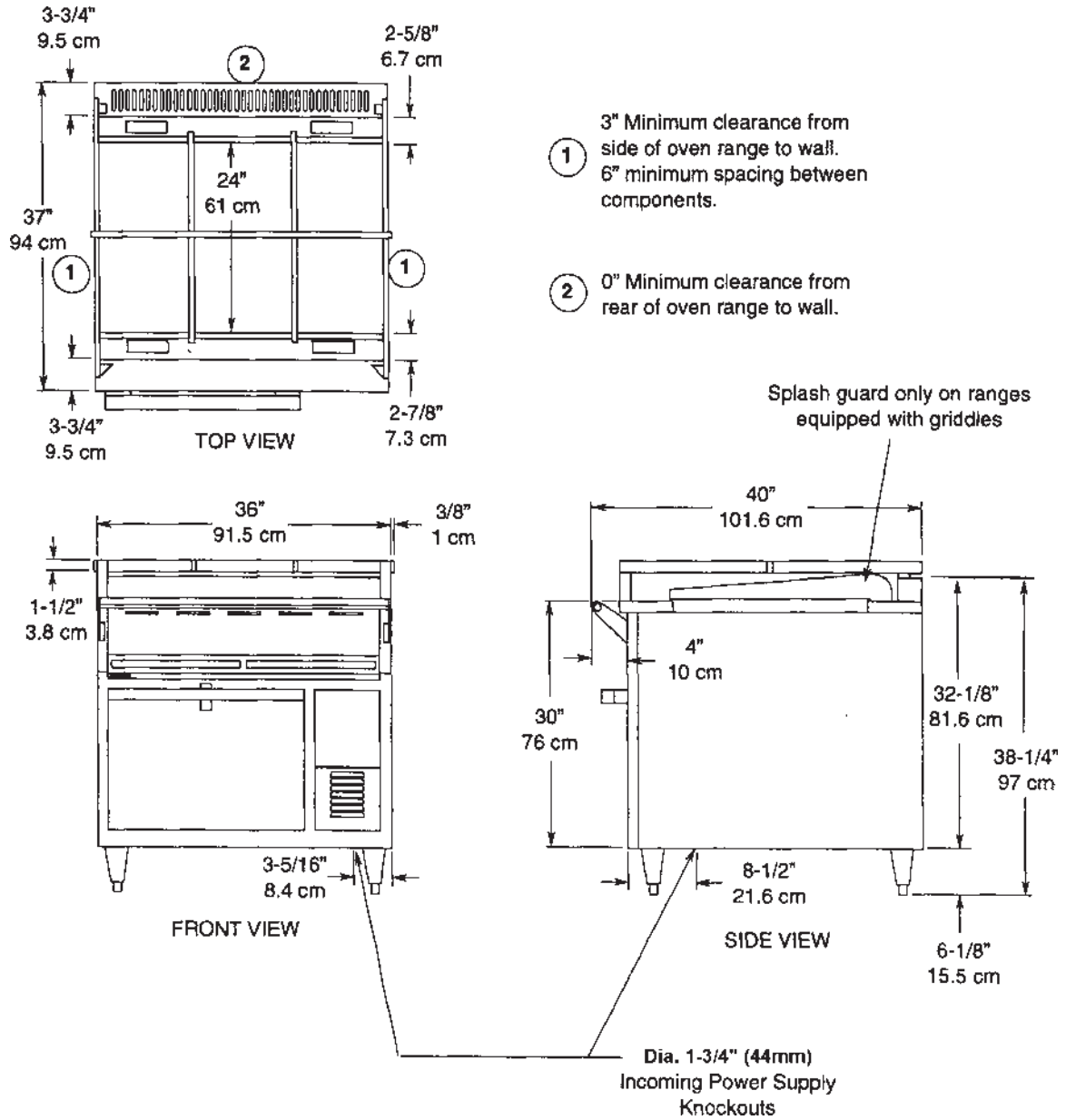

Figure 2-4

Section 2 - INSTALLATION

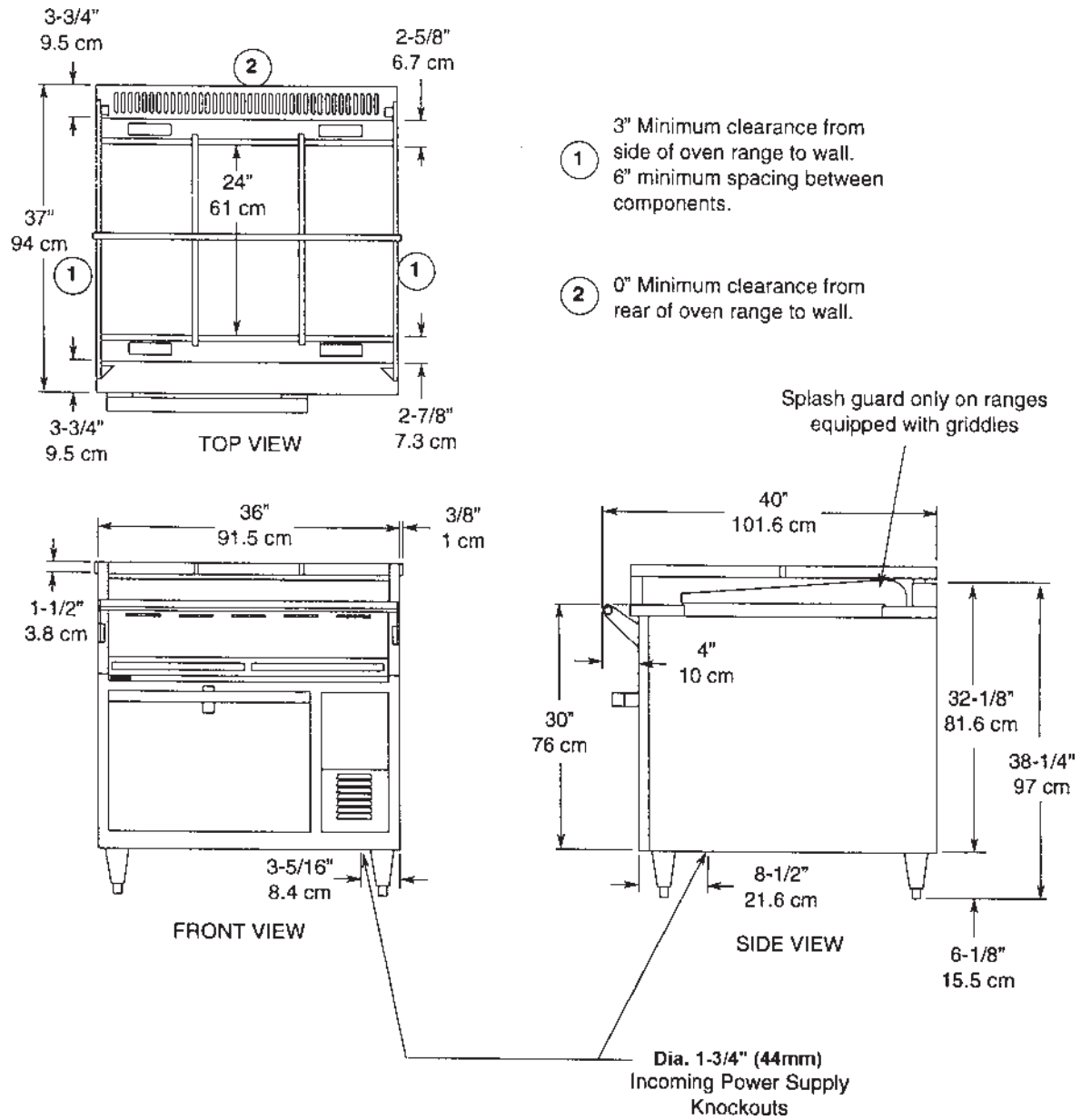
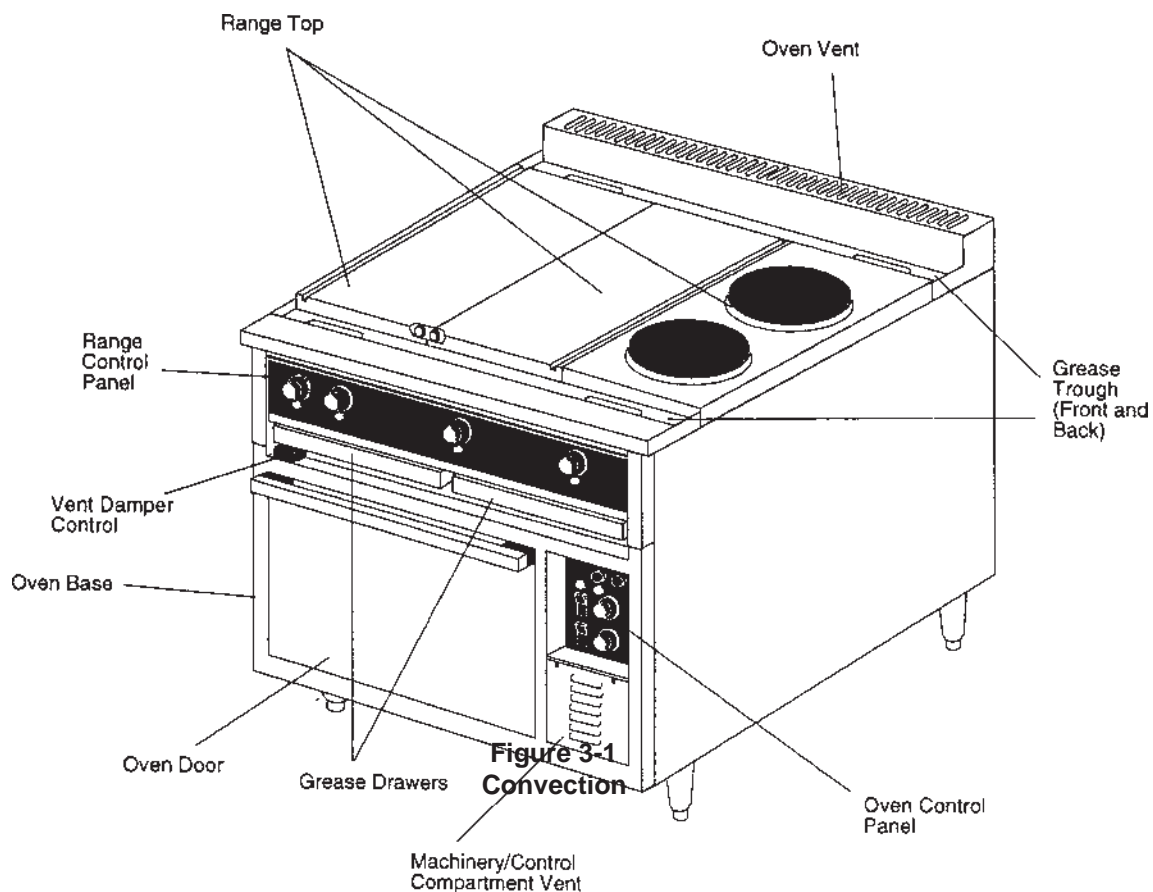

Figure 2-5

SECTION 3 OPERATION

I. COMPONENT FUNCTION AND LOCATION

- A. OVEN BASE Module** - either a convection oven or deck oven base.
Convection Oven heating element located on side of oven cavity with the blower fan.
Deck Oven has a heating element at both the top and bottom of the oven cavity.
- B. OVEN CONTROL PANEL** - All Oven operating controls and indicators.
- C. RANGE TOP** - Configured six different ways which consist of griddle, round hot plate, and/or 12" x 24" hot plate.
- D. RANGE TOP CONTROL PANEL** - Contains all operator controls for range top operation
- E. GREASE TROUGHS** - In front and behind the Range Top cooking surfaces. (Grease chutes provide drainage into the grease drawers)
- F. GREASE DRAWERS** - Containers for grease draining through the grease chutes from grease troughs.
- G. VENT DAMPER CONTROL** - Controls the amount of moisture that can be vented from the oven.



Section 3 - OPERATION

II. Control Functions and Locations

A. Convection Oven Control Panel

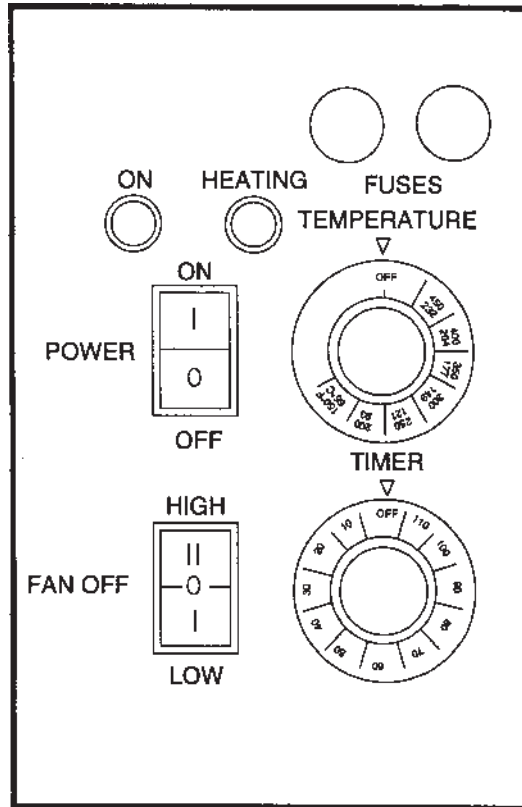

Figure 3-2
Convection Control Panel

- 1. Temperature Thermostat Control** - adjustable from 150°F to 450°F (65°C to 232°C). The thermostat is also provided with ON/OFF position. The oven will preheat to 450°F (232°C) in 15 minutes.
- 2. Heating Light** - Amber light signals when oven is coming up to set temperature and heating element is energized.
- 3. Power Switch** - turns ON or OFF.
- 4. On Light** - Green light signals when power is on.
- 5. Timer** - Adjustable from 6 to 120 minutes.
- 6. Fan Switch** - turns fan to LOW or HIGH speed and turns fan OFF. If fan switch is turned OFF the heating element will not heat. Fan switch must be positioned in LOW or HIGH for oven to function.
- 7. Fuse Holders** - Contains fuses.

B. Deck Oven Control Panel

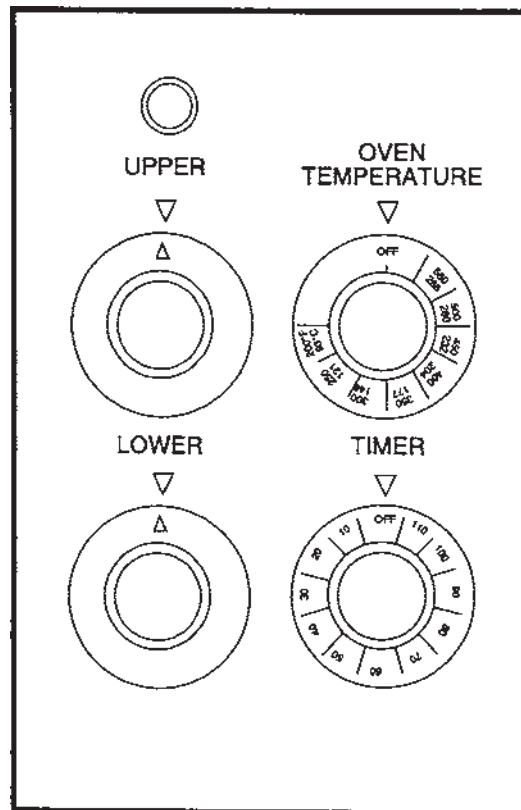

Figure 3-3
Deck Control Panel

- 1. Temperature Thermostat Control** - adjustable from 200°F to 500°F (93°C to 287°C). The thermostat is also provided with ON/OFF position. The oven will preheat to 450°F (232°C) in 20 minutes.
- 2. Upper and Lower Heating Element Switches** - are 3 position switches which adjust the heating elements at low, medium or high. The heating element switches also have an OFF position.
- 3. Heating Light** - Amber light signals when oven is coming up to set temperature and heating element(s) is energized.
- 4. Timer** - Adjustable from 6 to 120 minutes.

Section 3 - OPERATION

C. Range Top Controls

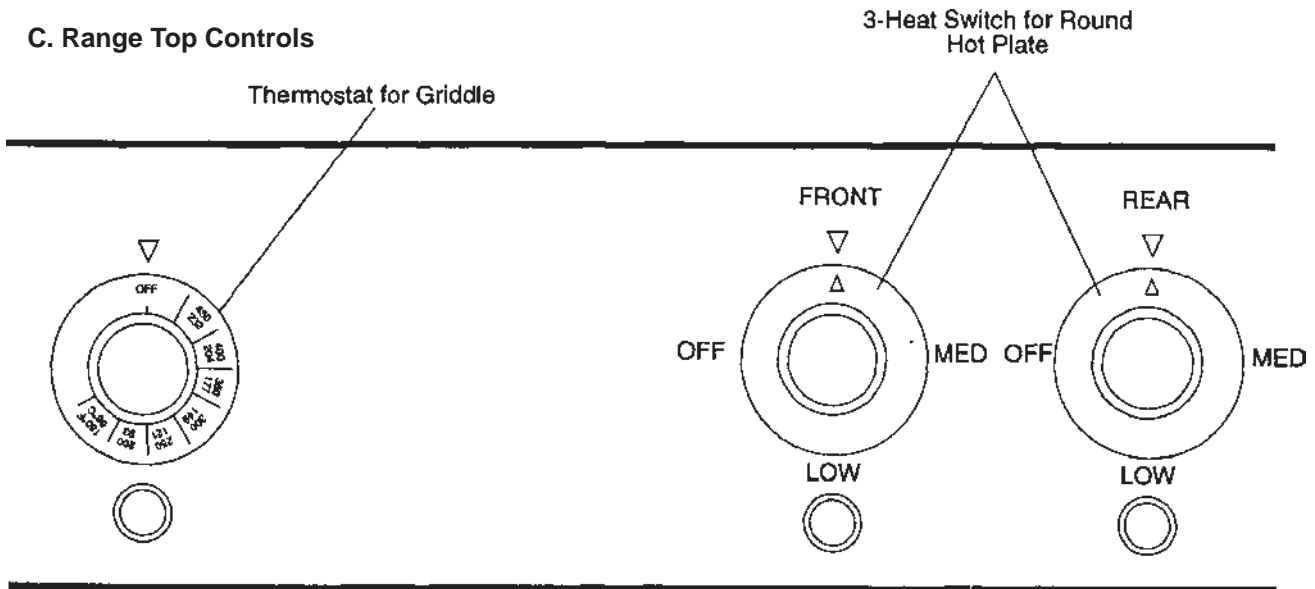

Figure 3-4

Range Top with Griddle Control

1. Griddle is controller by a Temperature Thermostat Control (see Figure 3-4) adjustable from 150°F to 450°F (65°C to 232°C). The griddle will preheat to 400°F (204°C) in 12 minutes. Adjacent green light remains on while heating elements are energized and griddle is coming up to set temperature.

Griddles have independent heat zones each with its own heating element and temperature control. The 24" x 24" griddle has two 12" heat zones and the 24" x 36" griddle has four 9" heat zones.

2. 12" x 24" Hot Plate is controlled by a Temperature Thermostat Control (see Figure 3-5) adjustable from 250°F to 850°F (121°C to 455°C). The 12" x 24" hot plate will preheat to 400°F (204°C) in 12 minutes. Adjacent green light remains on while heating elements are energized and griddle is coming up to set temperature.

3. Round Hot Plate is controlled by a 3-heat switch. The switch positions are LOW, MEDIUM, HIGH and OFF. Adjacent green light is always on while hot plate is on.

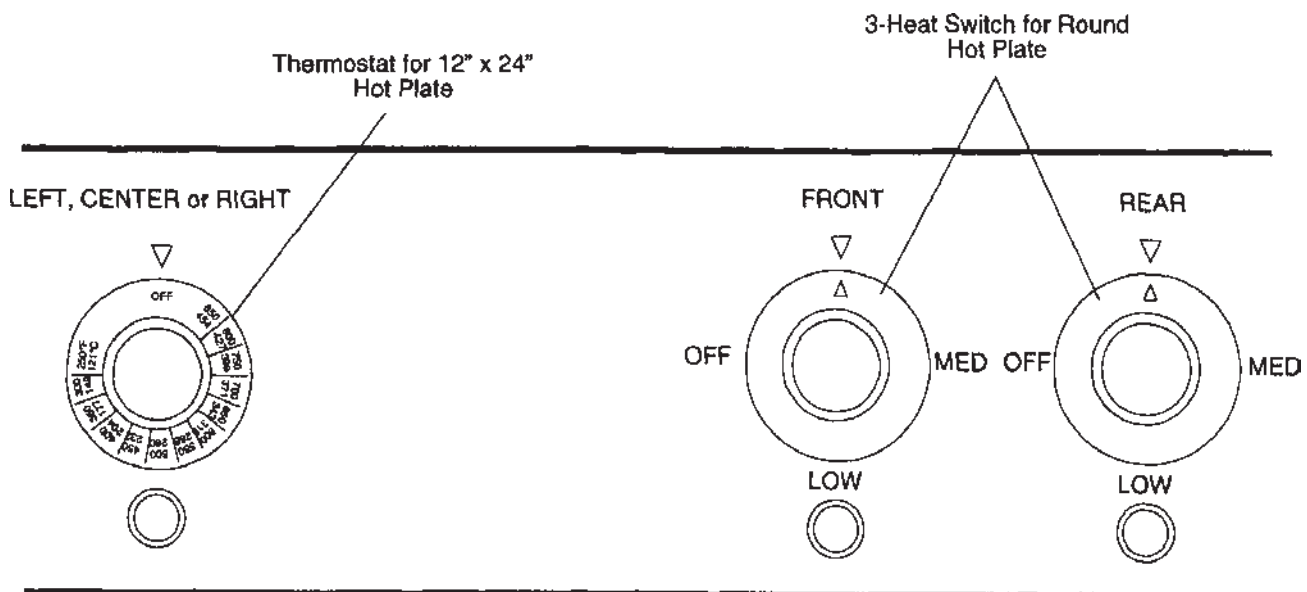

Figure 3-5

Range Top with Hot Plate Control



III. Operation

A. Convection Oven Operation

1. Set temperature control knob to the desired temperature.
2. Push the oven power switch to the ON position.
3. Push the fan switch to the HIGH or LOW position. The LOW fan speed should be used for delicate products or products with loose toppings such as pepperoni on a pizza. Use HIGH fan speed for all other products that will not be affected by a fast air movement.
4. Allow oven to preheat to the set temperature. The amber signal light will remain on until the temperature has been reached.
5. Place pans containing food products in oven and set timer for desired cook time. Refer to the Time and Temperature Charts on the following pages for suggested cook times and temperatures. When placing pans in oven do not block air flow on sides or in back of oven cavity. Blocking the air flow can cause uneven cooking.

Opening the oven door too often will also cause uneven cooking. Keep oven door closed except for necessary checking of food products.

6. Flue vent damper should be opened when cooking high moisture content foods. Pull the flue vent handle to open the vent damper.
7. When timer signal that cooking time has elapsed remove food product and turn power switch, temperature control and fan switch to OFF.

8. CONVECTION OVEN CLEANING

- a. At the end of the day's operation be sure the oven is turned off.
- b. Open the oven door and allow it to cool down.
- c. Remove the oven racks.
- d. Remove the oven rack hangers by lifting up and off the screw studs holding them in place.
- e. Remove the baffle surrounding the fan by removing the three screws on the front and pulling the baffle forward.
- f. All racks, rack hangers and fan baffle can be washed in warm soapy water, rinsed and wiped dry.
- g. Wash the blower wheel.
- h. Using a stiff brush (not wire), clean the interior of baked on food particles. Using a mild detergent and damp sponge wipe down the inside of the oven and door. Rinse and wipe dry. If these procedures are followed daily, it will prevent food particles from building up and creating hard to remove stains. Do not use strong abrasives as they will scratch the finish.

Section 3 - OPERATION

B. Deck Oven Operation

1. Set temperature control knob to the desired temperature.
2. Turn both Upper and Lower element switches to HIGH.
3. Allow oven to preheat to the set temperature. The amber signal light will remain on until the set temperature has been reached.
4. After oven is preheated set Upper and Lower element switches to desired setting (LOW, MEDIUM or HIGH).

When roasting, the best results are obtained by using balanced heat with both the Upper and Lower element switches on HIGH. A measured top heat provides excellent coloring and a caramelized finish to the meats, but where a seared or browned appearance is not desired, as in roasting fowl, the upper oven element switch should be set on MEDIUM, LOW or OFF.

5. Place pans containing food products into oven. For baking and roasting, pans should be placed on the intermediate rack. When roasting and baking pans are on both the deck and the rack the pans should be rotated halfway through the cooking cycle.

When placing pans in oven do not block air flow on sides or in back of oven cavity. Blocking the air flow can cause uneven cooking.

Opening the oven door too often will also cause uneven cooking. Keep oven door closed except for necessary checking of food products.

6. Set timer for desired cook time. Refer to the Time and Temperature charts on the following pages for suggested cook times and temperatures.
7. Flue vent damper should be opened when cooking high moisture content foods. Pull the flue vent handle to open the vent damper.
8. When the timer signals that cooking time has elapsed remove food product and turn temperature control and Upper and Lower element switches to OFF.

9. DECK OVEN CLEANING

- a. At the end of the day's operation be sure the oven is turned OFF.
- b. Open the oven door and allow it to cool down.
- c. Remove the oven rack and the oven deck at the bottom of the oven.
- d. Oven rack and deck can be washed in warm soapy water, rinsed and wiped dry.
- e. Using a stiff brush (not wire), clean the interior of baked on food particles. Using a mild detergent and damp sponge wipe down the inside of the oven and the oven door. Rinse and wipe dry. If these procedures are followed daily, it will prevent food particles from building up and creating hard to remove stains. Do not use strong abrasives as they will scratch the finish.

C. Griddle Operation

IMPORTANT: Do not turn griddle on before seasoning procedure has been completed.

IMPORTANT: If your griddle is new you must remove the rust preventative material before turning the griddle on. Refer to Section 2, Installation, Paragraph E.

1. Griddle Seasoning Procedure.

- a. Preheat the griddle to 300°F(149°C) and spread a light film of unsalted cooking oil or fat over the surface with a soft cloth.
- b. Allow griddle to stand this way for two minutes to give the oil an opportunity to work into the pores of the metal and to form a smooth coating over the outside.
- c. Wipe off excess oil and repeat Steps 1 and 2 at 350°F(175°C).
- d. After the second step is complete wipe off excess cooking oil, set thermostat control knob for desired temperature. The griddle is now ready for use.

2. Operating Hints and Safety

Although the finest materials, engineering and manufacturing facilities have provided for safety and trouble -free operation, only proper use and maintenance will assure personnel safety and long life of the equipment. The following are a few precautions and operating suggestions for use of the griddle.

- a. Disconnect power to the griddle at the disconnect switch at the end of each day of operation.
- b. Do not leave the griddle in operation without an attendant.
- c. Turn thermostat dials down to 200°F(93°C) during idle periods. It takes only a few minutes to regain operating temperatures.
- d. Do not heat the entire griddle for cooking small amounts of food.
- e. Various kinds of foods can be cooked at the same time by setting each section of the griddle at different temperatures.
- f. Use a spatula to push excess grease into troughs after each load of food is cooked. This will reduce smoking of hot grease and carbonizing.
- g. Do not leave griddle at high temperature when not in use or during idle periods. This will cause food particles and grease film to carbonize.

3. Daily Griddle Operation and Maintenance.

Daily Pre-Operation

- a. Season the griddle before operation daily, as described in Step 1 above.
- b. Turn the temperature controls to the desired temperature and allow 15 minutes or preheat time before loading griddle with food. Green signal light will remain on while heating elements are energized and griddle is coming up to set temperature. This will allow time for the griddle surface to be saturated with heat. Failure to allow sufficient preheat time will result in unsatisfactory cooking of the first load. The following chart indicates cooking time and temperature for various type of food.
- c. If a portion of the griddle is to be used for holding, then set the temperature controls for different temperatures.

Section 3 - OPERATION

Daily Post Operations:

a. Cleaning the Griddle Surface

AA. Good cooking requires clean equipment. To provide evenly cooked and perfectly browned foods, keep the griddle surface free fo carbonized grease. Carbonized grease on the griddle surface hinders the transfer of heat from the griddle surface to the food. This also results un spotty browning, decreased cooking efficiency, and worst of all, carbonized brease tends to cling to the griddled foods, giving them a highly unsatisfactory and unappetizinf appearance.

BB. At the end of each day of operation or at the end of each shift, thoroughly clean the front and rear grease troughs and the chutes into grease drawers.

CC. Clean the griddle surface with a pumice or griddle stone by rubbing with the grain of the metal while the griddle surface is still warm. Wipe griddle clean of residue from the griddle stone.

b. Clening - Wipe down sides of griddle and all areas around griddle to keep them free of splashed grease.

AA. Clean all surrounding surfaces of the griddle with warm water and a mild detergent daily.

BB. Rinse and wipe off excess water.

CC. Polish with a dry soft cloth.

NOTE: This simple treatment not only keeps the equipment dirt free and sparkling, it also eliminates the danger of grease accumulation forming hard to remove stains.

c. Cleaning the grease drawer - Empty each gresae drawer as often as necessary, but they must be emptied at the end of ech day of operation or the end of each shift. Also wash out grease drawers with hot water and a mild detergent. Wipe dry and replace in range. NOTE: Marine ranges are equipped with a grease drawer latch which must be held depressed as the grease drawers are removed.

D. 12" x 24" Hot Plate Operation

IMPORTANT: If your hot plate is new you must remove the rust preventative material before turning the griddle on. Refer to Section 2, Instalaltion, Paragraph E.

1. Turn the temperature controls to the desired temperature and allow 15 minutes of preheat timer before using the hot plate. the green signal light will remain on while the heating elements are energized and the hit plate is coming up to set temperature.
2. When hot plate is preheated place pots or vessels onto hot plate for cooking.
3. HOT PLATE CLEANING.
 - a. Wash range with warm soapy water, rinse and wipe dry.
 - b. Be sure to clean all surfaces around and on the hot plates.
 - c. Polish with a soft cloth.

E. Round Hot Plate Operation

1. Turn the 3-heat switch to LOW, MEDIUM or HIGH. Allow the hot plate to preheat for 10 minutes and then place pots or vessels onto hot plate for cooking.
2. Green signal light will remian on until 3-heat switch is turned to the OFF position.
3. ROUND HOT PLATE CLEANING
 - a. Wash range with warm soapy water, rinse and wipe dry.
 - b. Be sure to clean all surfaces around and on the hot plates.
 - c. Polish with a soft dry cloth.

F. Marine Ranges

Marine ranges are provided with a full width grab bar, 6" marine bolt down legs, and oven door latch and sea rails to prevent movement of pots on range top.

The range top sea rails may have to be repositioned when various size pots or vessels are used.

Section 3 - OPERATION

IV. Time and Temperature Charts

DECK OVEN BAKING TIME AND TEMPERATURE

PRODUCT	TEMPERATURE	TOP SWITCH	BOTTOM SWITCH	TIME IN MINUTES
Two Crust Pies	400°F - 425°F(204°C - 218°C)	Medium	High	40-60
Open Face Pies	400°F - 425°F(204°C - 218°C)	Medium	High	35-50
Pumpkin Pies	375°F - 400°F(190°C - 204°C)	Medium	Medium	35-50
Custard Pies	375°F - 400°F(190°C - 204°C)	Medium	Medium	35-50
Meringue Pie (Brown)	425°F - 450°F(218°C - 232°C)	High	Off	5-6
Pie Shells	400°F - 425°F(204°C - 218°C)	Medium	Medium	20-30
Parker House Rolls	400°F - 425°F(204°C - 218°C)	Medium	Medium	20-30
Whole Wheat Rolls	375°F - 400°F(190°C - 204°C)	Medium	Medium	20-30
Danish Rolls	375°F - 400°F(190°C - 204°C)	Medium	Medium	20-30
Sweet Rolls	375°F - 400°F(190°C - 204°C)	Medium	Medium	20-30
Kolacky	375°F - 400°F(190°C - 204°C)	Medium	Medium	10-15
Tea Biscuits	375°F - 400°F(190°C - 204°C)	Medium	Medium	20-25
Corn Bread	400°F - 425°F(204°C - 218°C)	Medium	Medium	25-35
Cup Cakes	400°F - 425°F(204°C - 218°C)	Medium	Medium	15-20
Layer Cakes	350°F - 375°F(176°C - 190°C)	Medium	Medium	20-30
Loaf Cakes	350°F - 375°F(176°C - 190°C)	Off	Medium	45-60
Angel Food Cakes	300°F - 325°F(149°C - 163°C)	Medium	Medium	40-50
Puddings	325°F - 375°F(163°C - 190°C)	Medium	Medium	35-60
Baked Apples	300°F - 325°F(149°C - 163°C)	Low	Low	60-70

* Used when the crust and filling are baked as a unit. When the crust is pre-baked most bakers use a temperature of approximately 300°F - 350°F(149°C - 176°C).

NOTE: The data in this chart is of a general nature and is suggested for use as a guide only. Experience will, of course, dictate variations that best fit your baking requirement.

DECK OVEN ROASTING TIME AND TEMPERATURE

PRODUCT	CONTROL SETTING	INTERNAL MEAT TEMPERATURE	MINUTES PER POUND
Beef			
Standing Rib. 3 Rib. 6-8 Pounds	300°F(149°C)	Rare 140°F(60°C)	20
		Med. 160°F(71°C)	25
		Well 170°F(77°C)	30
Standing Rib. 7 Rib. 20-25 pounds	300°F(149°C)	Rare 125°F(52°C)	13
		Med. 140°F(60°C)	15
		Well 150°F(65°C)	17
Rolled Rib. 7 Rib. 16-18 pounds	250°F(121°C)	Well 150°F(65°C)	25
Rump or Chuck. 8-23 pounds	300°F(149°C)	140°F - 170°F(60°C - 77°C)	20 - 30
Round Rump. shank off. 50 pounds	300°F(149°C)	140°F - 170°F(60°C - 77°C)	12 - 16
Lamb			
Leg. 7-8 pounds	300°F(149°C)	180°F(82°C)	30 - 35
Leg. 15-20 pounds	300°F(149°C)	160°F(71°C)	20 - 30
Shoulder	300°F(149°C)	180°F(82°C)	40 - 45
Breast, Stuffed	300°F(149°C)	175°F - 180°F(79°C - 82°C)	30 - 35
Pork			
Ham Leg, 15 pounds	350°F(176°C)	185°F(85°C)	30 - 35
Ham Leg, 25 pounds	350°F(176°C)	185°F(85°C)	30 - 35
Ham Boned, 15 pounds	350°F(176°C)	185°F(85°C)	30 - 35
Loin	350°F(176°C)	185°F(85°C)	
Boston Butt	350°F(176°C)	185°F(85°C)	45 - 50
Ham. Cured. 20 pounds	300°F(149°C)	160°F(71°C)	15 - 18
Veal			
Leg. 16 pounds	300°F(149°C)	170°F(77°C)	22
Leg. 25 pounds	300°F(149°C)	170°F(77°C)	18 - 20
Shoulder. 15 pounds	300°F(149°C)	170°F(77°C)	25
Shoulder. Rolled. 15 pounds	300°F(149°C)	170°F(77°C)	35 - 40
Loin. 10 pounds	300°F(149°C)	170°F(77°C)	25 - 30
Fowl			
Chicken. Dressed. 4-6 pounds	250°F - 300°F(121°C - 149°C)	190°F(88°C)	35 - 40
Duck. Dressed. 5-8 pounds	300°F(149°C)	190°F(88°C)	25 - 30
Turkey. Dressed. 14-19 pounds	300°F(149°C)	190°F(88°C)	20 - 25
Turkey. Dressed. 27-33 pounds	300°F(149°C)	190°F(88°C)	15 - 20

NOTE: The above data is of general nature. Many factors such as size of bone, thickness of meat, temperature at time of roasting, individual taste as to degree of doneness, seasoning, etc., must be taken into consideration. Pan selection and cooking times will also be governed by total weight, number of pieces in load. Preheating for roasting is unnecessary.

Section 3 - OPERATION

CONVECTION OVEN BAKING TIME & TEMPERATURE

This chart provides recommended temperature and time settings plus a number of racks per oven for specific food products. The times and temperature may, however, vary considerably due to weight of load, type of utensils and recipe.

PRODUCT	SIZE OF PAN	NO. OF RACKS	YIELD	TEMP SETTING	TIME SETTING
Frozen Berry Pies, 22 oz,	9" dia	3	18	350°F(176°C)	34min
Frozen Fruit Pies, 46 oz	9" dia	3	12	350°F(176°C)	45-50min
Frozen Apple Pies, 22 oz	9" dia	3	18	350°-375°F(176°-190°C)	25-30min
Sheet Cake	18" x 26"	3	3	335°F(168°C)	16-18min
Corn Bread	18" x 26"	3	3	335°F(168°C)	25min
Bread, 1lb Loaves		2	16	340°F(171°C)	30min
Sugar Cookies, 3" dia	18" x 26"	3	144	300°F(149°C)	15min
Brownies	12" x 20" x 2"	3	6	350°F(176°C)	15min
Beef Pot Pies, 5" dia	5" dia	3	60	400°F(204°C)	30-35min
Turkey or Chicken Pot Pies	5" dia	3	60	400°F(176°C)	30-35min
Stuffed Peppers		2		350°F(176°C)	15-20min
Toasted Cheese Sandwiches	12" x 20"	3	90	400°F(204°C)	8min
Hamburger Patties, 5 per lb.	18" x 26"	5	144	400°F(204°C)	8-10min
Chicken, Qtrs. (2-1/2lb avg)	18" x 26"	3	75	350°F(176°C)	30min
Chicken Breast - Thigh	18" x 26"	3		350°F(176°C)	40min
Individual Pizza (Frozen)	5" dia	3	60	450°F(232°C)	5min
Halibut Steaks (5oz Frozen)	18" x 26"	3	90	350°F(176°C)	20min
Rolled Roast Beef (20lb. Avg)		2	80	300°F(149°C)	4 hours
Meat Loaf		2		325°F(163°C)	40-45min
Idaho Potatoes (8oz Avg)	20 per rack	3	60	400°F(204°C)	50min



GRIDDLE TIME AND TEMPERATURE

NOTE: All cooking times are approximate

PRODUCT	CONTROL TIME SETTING	ADVANCE IN MINUTES	PREPARATIONS
Canadian Bacon	350°F(176°C)	3 - 4	Slice (not too far in advance as meat will darken) - Split edges to prevent curling.
Hamburgers	350°F(176°C)	3 - 4	Prepare recipe - Form patties - Separate with waxed paper - Refrigerate.
Cheeseburgers	350°F(176°C)	3 - 4	A hamburger patty plus melt a slice of cheese on top just before serving.
Corned Beef Patties	375°F(190°)	3 - 4	Open both ends of can - Slide out contents of can - Cut into 3/8" slices.
Sausage Patties	350°F(176°C)	3 - 4	Form patties - Separate with waxed paper - Refrigerate.
Sausage Links	350°F(176°C)	3	Refrigerate for best results.
Potato Patties	375°F(190°)	3 - 4	Cook-Mash-Season-Form patties using 1/4 cup measure.
American Fries Potatoes	375°F(190°)	3 - 4	Cook - Slice - Season.
French Toast	400°F(204°C)	4 - 5	Prepare egg batter.
Scrambled Eggs	300°F(149°C)	3 - 4	Prepare recipe
Pancakes	375°F(190°)	2	Prepare recipe.
Frankfurters	375°F(190°)	2 - 5	
Minute Steaks	400°F(204°C)	3 - 4	
Club Steaks	400°F(204°C)	3 - 5	
Ham Steaks	400°F(204°C)	10	
Beef Tenderloin	400°F(204°C)	5 - 7	
Boiled Ham	375°F(190°)	2	
Bacon	350°F(176°C)	6	
Hard Fried Eggs	300°F(149°C)	3	
Soft Fried Eggs	300°F(149°C)	2	
Sunny-Side Up Eggs	300°F(149°C)	3	

NOTES

SECTION 4 PARTS LIST

**Order parts by calling your
authorized Toastmaster Parts
Distributor, who has a complete
inventory of parts for all Toastmaster
equipment.**

Section 4 - PARTS LIST

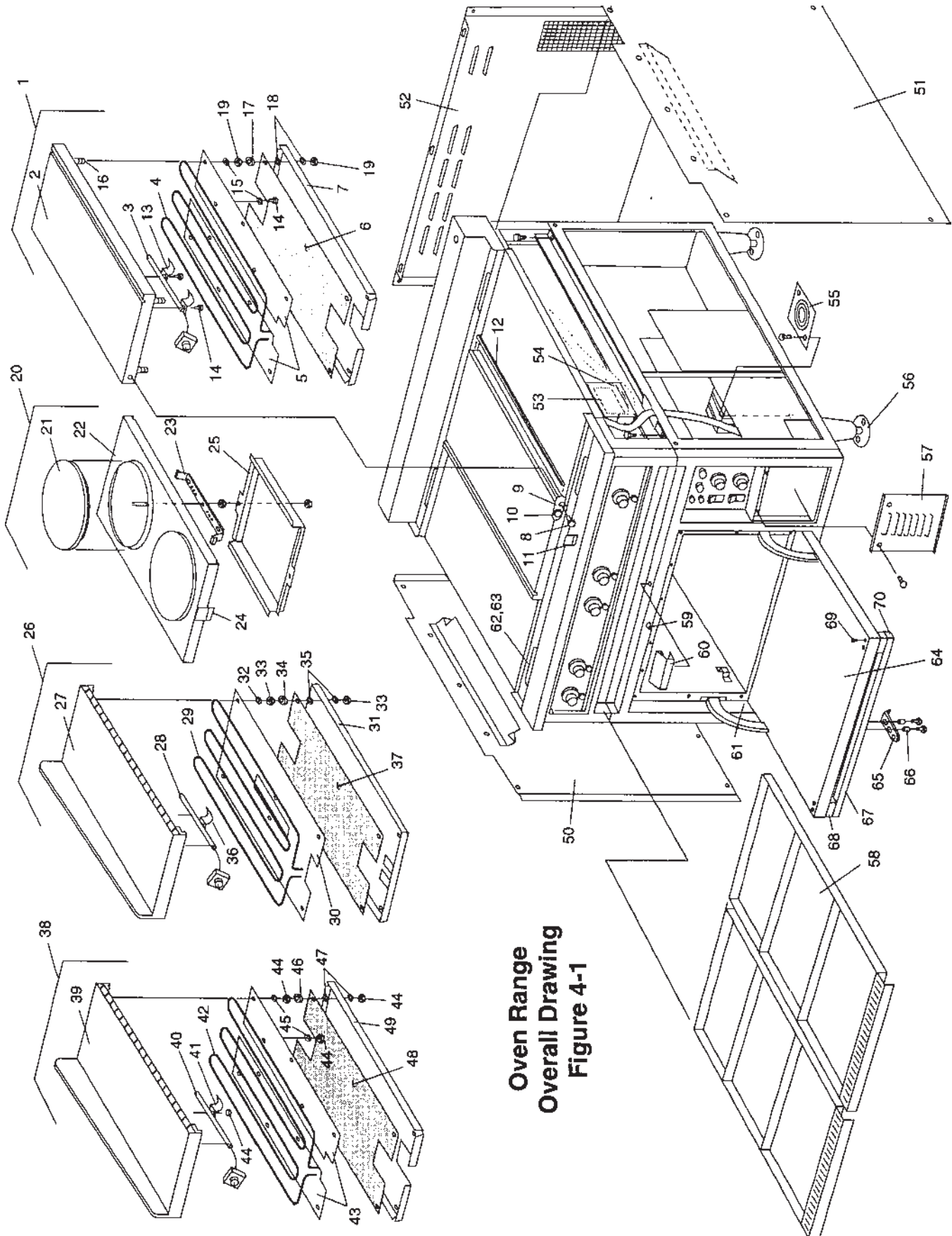

Oven Range
Overall Drawing
Figure 4-1



Section 4 - PARTS LIST

RH36 & MH36			
OVERALL PARTS LIST			
Item No	Qty	Part No	Description
1	1	N2-7600083	12x24 PLATE CMPLT - RIGHT DRAIN 208V
		N2-7600084	12X24 PLATE CMPLT - RIGHT DRAIN 240V
		N2-7600086	12X24 PLATE CMPLT - RIGHT DRAIN 480V
		N2-7600087	12X24 PLATE CMPLT - LEFT DRAIN 208V
		N2-7600088	12X24 PLATE CMPLT - LEFT DRAIN 240V
		N2-7600090	12X24 PLATE CMPLT - LEFT DRAIN 480V
		N2-7600074	12X24 PLATE CMPLT - CENTER 208V
		N2-7600075	12X24 PLATE CMPLT - CENTER 240V
		N2-7600077	12X24 PLATE CMPLT - RIGHT DRAIN 480V
		N2-7601872	12X24 PLATE CMPLT - DRAIN BOTH SIDES 208V (USED ON MODELS RH3607 & RH36D7)
		N2-7601873	12X24 PLATE CMPLT - DRAIN BOTH SIDES 240V (USED ON MODELS RH3607 & RH36D7)
		N2-7601875	12X24 PLATE CMPLT - DRAIN BOTH SIDES 480V (USED ON MODELS RH3607 & RH36D7)
2	1	N2-20XA1G1	12X24 PLATE ONLY DRAIN BOTH SIDES
	2	N2-20A2G8	12X24 PLATE ONLY RIGHT OR LEFT
	1	N2-20A2G9	12X24 PLATE ONLY CENTER
3	3	2T-3004281	THERMOSTAT
		2R-2100094	T-STAT KNOB 250°F (121°C) - 850°F (454°C)
4	3	2N-F706A8703	ELEMENT 208V
		2N-F706A8731	ELEMENT 240V
		2N-F706A8729	ELEMENT 480V
5	6	N2-20A2G1	ELEMENT CLAMP PLATE
6	3	1O-8500079	INSULATION
7	3	N2-F706A107	BAFFLE
8	4	2C-20A2G7	LATCH SCREW
9	4	N2-20A2G6	LATCH PLATE
10	4	2A-20A1G7	LATCH PIN
11	4	N2-34284	CLIP, RETAINING 12X24 HOTPLATE
12	2	N2-20A1G8	KEY STRIP
13	6	N2-F706A1013	BULB CLAMP
14	27	2C-F716A8803	CAP SCREW 1/4-20 X 3/8
15	30	2C-F706A8809	WASHER 1-1/4"
16	12	2C-2001184	STUD 1/4-20 X 1-5/8
17	12	2A-F706A8811	SPACER
18	30	2C-F706A8805	WASHER 1/4"
19	24	2C-F706A8807	HEX NUT 1/4-20, BRASS
20	1/3	N2-34797	TWIN PLATE ASSEMBLY 208V, 2600W
		N2-33850	TWIN PLATE ASSEMBLY 240V, 2600W
		N2-34278	TWIN PLATE ASSEMBLY 480V
21	2/6	2N-1132B8701	SOLID RND HEATING UNIT 208V ECO-2600W
		2N-1132B8703	SOLID RND HEATING UNIT 240V ECO-2600W
		2N-34127	SOLID RND HEATING UNIT 480V ECO-2600W
22	1/3	N2-7610114	TWIN PLATE PANEL
23	1/3	N2-1132B8901	RETAINER BAR MOUNTING BRACKET
24	2/6	N2-34285	RETAINING CLIP
25	1/3	N2-30999	BOTTOM. PLATE

Item No	Qty	Part No	Description
26	1	N2-20G1A32	36X24 GRIDDLE PLATE CMPLT 208V
		N2-20G1A302	36X24 GRIDDLE PLATE CMPLT 240V
		N2-20G1A306	36X24 GRIDDLE PLATE CMPLT 480V
27	1	N2-20G1A36	36X24 GRIDDLE PLATE ONLY
28	4	2T-3004257	THERMOSTAT
		2R-2100059	T-STAT KNOB 150°F (66°C) - 450°F (232°C)
29	4	2N-7D1E1	ELEMENT 208V
		2N-7D1E29	ELEMENT 240V
		2N-7D1E28	ELEMENT 480V
30	4	N2-20G1A37	ELEMENT CLAMP PLATE
31	4	N2-20G1A38	ELEMENT BAFFLE
32	24	2C-F706A8802	WASHER 11/32 X 1-1/4
33	48	2C-F706A8807	HEX NUT, BRASS 1/4-20
34	24	2A-F706A8811	SPACER
35	28	2C-F706A8805	WASHER 1/4"
36	4	N2-7002270	THERMOSTAT BULB CLAMP
37	4	1O-8500079	INSULATION
38	1	N2-7603538	24X24 GRIDDLE PLATE CMPLT 208V
		N2-7603539	24X24 GRIDDLE PLATE CMPLT 240V
		N2-7603541	24X24 GRIDDLE PLATE CMPLT 480V
39	1	N2-7603536	24X24 GRIDDLE PLATE ONLY
40	2	2T-3004257	THERMOSTAT
		2R-2100059	T-STAT KNOB 150°F (66°C) - 450°F (232°C)
41	4	N2-F706A1013	THERMOSTAT BULB CLAMP
42	2	2N-F706A8703	ELEMENT 208V
		2N-F706A8731	ELEMENT 240V
		2N-F706A8729	ELEMENT 480V
43	4	N2-20A2G1	ELEMENT CLAMP PLATE
44	26	2C-B301A8817	HEX NUT 1/4-20
45	20	2C-F706A8809	WASHER 1-1/4" OD
46	8	2A-F706A8811	SPACER
47	16	2C-F706A8805	WASHER 1/4"
48	2	1O-8500079	INSULATION
49	2	N2-F706A1017	BAFFLE
50	1	N2-33617	WELDMENT, EXT. PANEL LEFT HAND
51	1	N2-33618	WELDMENT, EXT. PANEL RIGHT HAND
52	1	N2-32849	REAR PANEL
53	1	2E-30905	TERMINAL BLOCK, 3-POLE
54	1	N2-33616	PLATE COVER
55	1	N2-7007442	KNOCKOUT PLATE
56	1	N2-MALG06F	KIT, MARINE LEG 6" SS ADJ.
57	1	N2-7007992	ACCESS PANEL
58	2	N2-7601840	GREASE DRAWER, HANDLE & ASSEMBLY
59	1	N2-32691	LATCH, MARINE
60	2	N2-34743	LATCH, GREASE DRAWER
		N2-34741	RECIEVER FOR LATCH
61	2	2A-33621	DOOR BUSHING
62	4	N2-7610657	WELDMENT, SPOUT GREASE

RH36 & MH36 CONTINUED			
Item No	Qty	Part No	Description
63	4	2I-2700090	GASKET, SPOUT GREASE
64	1	N2-33693	ASSEMBLY, DOOR
65	1	N2-32692	PLATE, LATCH
66	2	2A-34081	SPACER, STEPPED - MARINE LATCH
67	1	N2-32572	ASSEMBLY, HANDLE DOOR
68	2	2A-3103164	SPACER, DOOR & DRAWER HANDLE
69	4	2V-2000320	HANDLE SCREWS 10/32 X 3-12
70	2	2V-3000058	BLACK HANDLE PLUG
NI	--	2M-31795	DECAL RH36C3, RH36D3 CONTROL PANEL
		2M-31796	DECAL RH36C4, RH36D4 CONTROL PANEL
		2M-31794	DECAL RH36C2&C6, RH36D2&D6 CONTROL PANEL
		2M-31793	DECAL RH36C1&C7, RH36D1&D7 CONTROL PANEL
		N2-30926	CONTROL PANEL RH36D4
		N2-31623	CONTROL PANEL RH36C3

NOTES

Section 4 - PARTSLIST

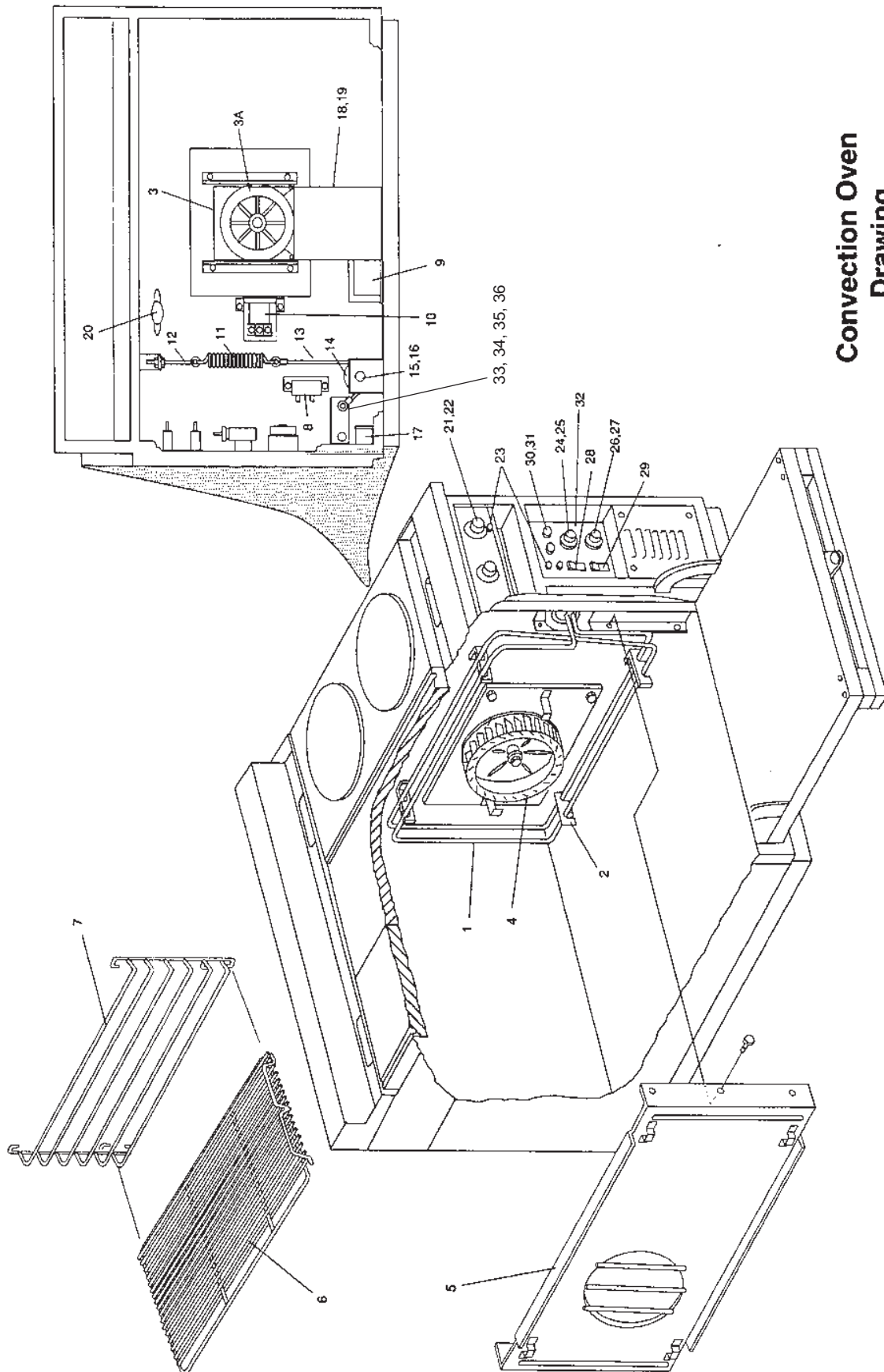

Convection Oven
 Drawing
 Figure 4-2
 IL2012

Section 4 - PARTS LIST

RH36 & MH36			
CONVECTION OVEN PARTS LIST			
Item No	Qty	Part No	Description
1	1	2N-3027A8701	ELEMENT 6000W-208V
		2N-3027A8711	ELEMENT 6000W-240V
		2N-3027A8709	ELEMENT 6000W-480V
2	4	N2-3027A3083	ELEMENT SUPPORT
3	1	N2-30919	MOTOR BLOWER & ASSEMBLY 240V-480V
3A	1	2U-3002761	BLOWER MOTOR ONLY 208V-240V
4	1	2R-3103902	BLOWER WHEEL
5	1	N2-7610513	ELEMENT COVER, BLOWER BAFFLE
6	3	N2-3102541	SHELF ASSEMBLY
7	2	2B-3102540	SIDE RACK
8	1	2E-30905	TERMINAL BLOCK, 3-POLE
9	1	2E-28082-0010	TRANSFORMER 480V ONLY
10	1	2E-34401	CONTACTOR 208V-240V COIL
11	1	2P-30368	DOOR SPRING
12	1	2C-43685	EYE BOLT
13	1	N2-30369	CABLE ASSEMBLY
14	1	2R-7007809	PULLEY
15	1	2A-30359	AXLE
16	2	2C-3102937	RETAINER RING
17	1	2E-3003770	MICRO SWITCH
18	1	N2-32762	MOTOR DUCT
19	1	2I-34404	MOTOR DUCT SEAL
20	1	2E-30519	HIGH LIMIT SENSOR
21	AR	2E-32941	SWITCH 3HT
22	AR	2R-33365	KNOB SWITCH
23	AR	2E-33413	SIGNAL LIGHT, GREEN 250V
		2E-33414	SIGNAL LIGHT, AMBER 250V
		2E-33415	SIGNAL LIGHT, WHITE 250V
		2E-33417	SIGNAL LIGHT, GREEN 480V
		2E-33418	SIGNAL LIGHT, AMBER 480V
		2E-33419	SIGNAL LIGHT, WHITE 480V
24	1	2T-2662A8701	THERMOSTAT, C.O. OVEN 150F (66C)-450F (232C)
25	1	2R-A710E8771	THERMOSTAT KNOB, C.O. OVEN 150°F (66°C) - 450°F (232°C)
26	1	2P-3004536	TIMER
27	1	2R-2100088	OVEN TIMER KNOB
28	1	2E-33436	SWITCH, ROCKER, DP/ST
29	1	2E-33437	SWITCH, ROCKER DP/DT
30	2	2E-1455A0341	FUSE HOLDER ASSEMBLY 480V
		2E-1455A0339	FUSE HOLDER ASSEMBLY 240V
31	2	2E-1455A8793	FUSE 240V-10A
		2E-1455A8794	FUSE 480V-10A
32	1	2M-91783	DECAL CONTROL PANEL (not shown)
33	AR	34700	BOLT
34	AR	3024A3141	BUSHING
35	AR	18A1S-2	COTTER PIN
36	AR	21176-0001	LOCK NUT

SUPPORTED BY SOUTHBEND

Section 4 - PARTS LIST

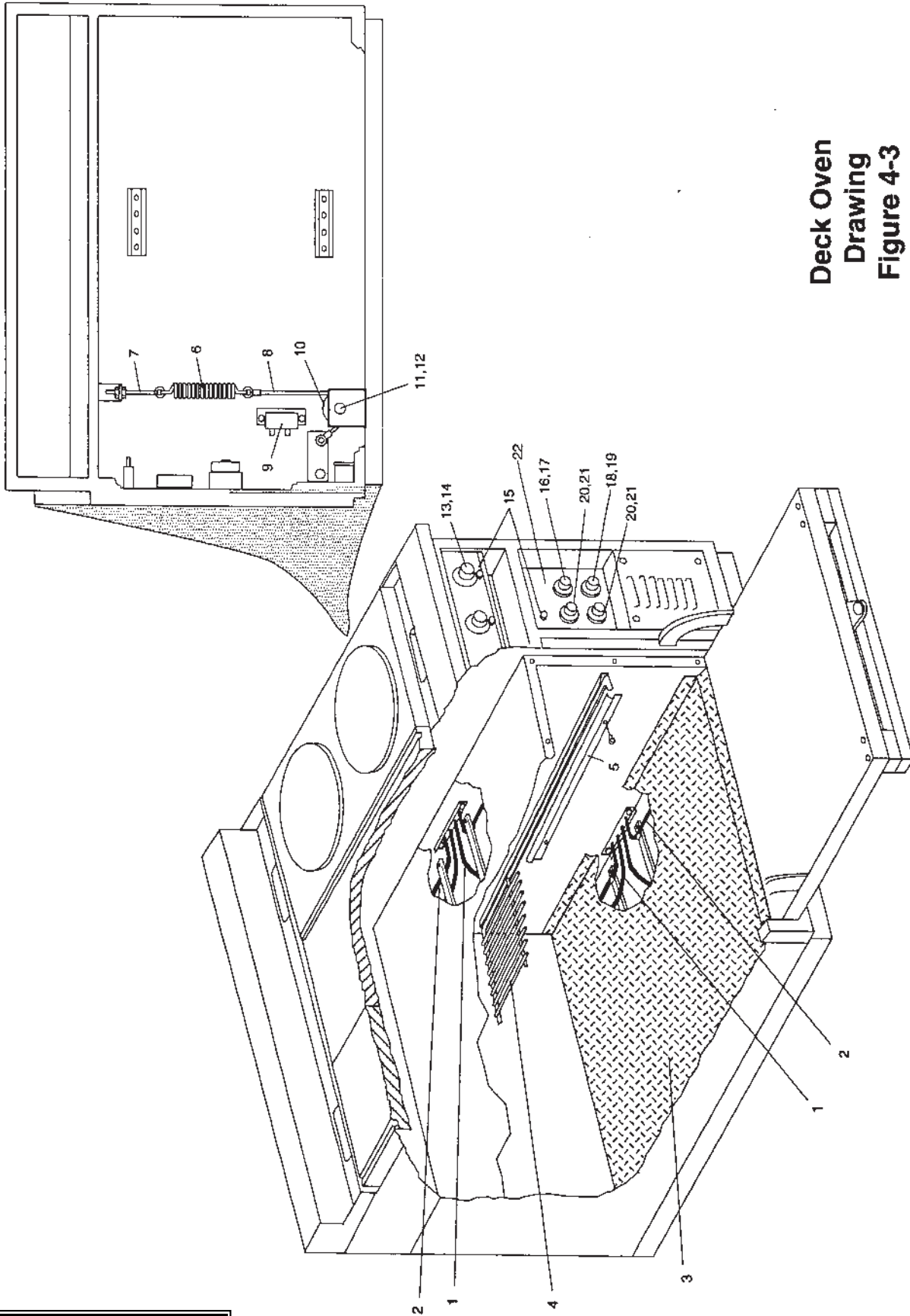

Deck Oven
Drawing
Figure 4-3

RH36 & MH36			
DECK OVEN PARTS LIST			
Item No	Qty	Part No	Description
1	2	2N-3001761	INNER ELEMENT 1500W-208V
		2N-3001762	INNER ELEMENT 1500W-240V
		2N-3001764	INNER ELEMENT 1500W-480V
2	2	2N-3001765	OUTER ELEMENT 1500W-208V
		2N-3001766	OUTER ELEMENT 1500W-240V
		2N-3001768	OUTER ELEMENT 1500W-480V
3	1	N2-30692	OVEN DECK
4	1	N2-30372	OVEN SHELF
5	1	N2-3024A3217	GUARD THERMOSTAT BULB
6	1	2P-30368	SPRING, DOOR
7	1	2C-43685	EYEBOLT
8	1	N2-30369	CABLE ASSEMBLY
9	1	2E-30905	TERMINAL BLOCK, 3POLE
10	1	2ER-7007809	SHEAVE, 3/16 DIA. CABLE (PULLEY)
11	1	2A-30359	AXLE
12	2	2C-3102937	RETAINER RING
13	2/6	2E-32941	SWITCH 3HT
14	2/6	2R-33365	KNOB SWITCH
15	AR	2E-33413	SIGNAL LIGHT, GREEN 250V
		2E-33414	SIGNAL LIGHT, AMBER 250V
		2E-33417	SIGNAL LIGHT, GREEN 480V
		2E-33418	SIGNAL LIGHT, AMBER 480V
16	1	2T-3004238	THERMOSTAT DECK OVEN
17	1	2R-A710E8739	THERMOSTAT KNOB DECK OVEN 200°F-550°F
18	1	2P-3004536	TIMER
19	1	2R-210088	KNOB, TIMER
20	2	2E-32941	SWITCH 3HT
21	2	2R-33365	KNOB SWITCH
22	1	2M-31784	DECAL CONTROL PANEL DECK OVEN

Section 4 - PARTS LIST

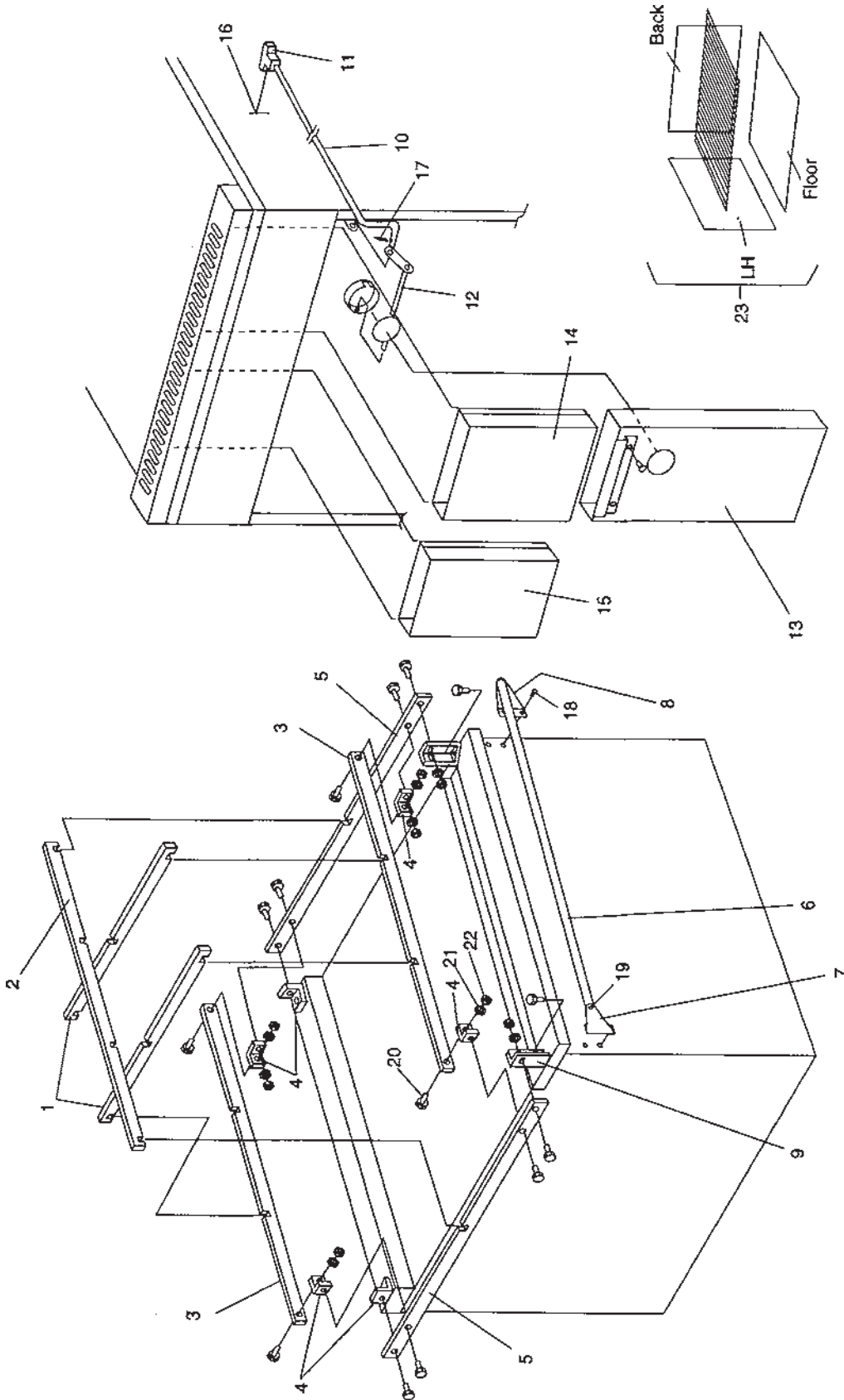

Vents & Marine Rails
Drawing
Figure 4-4

RH36 & MH36			
VENTS & MARINE RAILS PARTS LIST			
Item No	Qty	Part No	Description
1	2	N2-33194	RAIL, SEA FRONT TO BACK LOOSE
2	1	N2-33195	RAIL, SEA LEFT TO RIGHT LOOSE
3	2	N2-20A2C77	RAIL, SEA FIXED RIGHT LEFT
4	6	N2-20A2C76	ANLE, SEA RAIL SECURITY
5	2	N2-20A2C75	RAIL, SEA FIXED FRONT BACK
6	1	N2-20A2C82	RAIL, HAND
7	1	N2-7001408	BRACKET, RAIL LIT MARINE
8	1	N2-7001409	BRACKET, RAIL RT MARINE
9	2	N2-7004267	POST, SEEA RACKS
10	1	2V-7000071	ROD, VENT RA
11	1	2R-2100053	KNOB, VENT "T" PULL/OPEN
12	1	N2-7610705	WELDMENT, FLAP VENT
13	1	N2-30412	WELDMENT, FLUE - OVEN SECTION
14	1	N2-30415	WELDMENT, FLUE - TOP SECTION
15	1	N2-32792	WELDMENT, FLUE - TOP SECTION
16	1	2A-2002305	VENT KNOB PIN
17	1	2C-18A12	COTTER PIN
18	4	2C-2000552	SCREW 5/16-18 X 3/4
19	2	2C-4113A8801	SCREW FHM 1/4-20 X 1/2
20	16	2C-2281	SCREW 5/16-18 X 7/16
21	16	2C-4039A8803	LOCKWASHER 5/16
22	12	2C-1411D8815	HEX NUT 5/16-18
23	1	N2-34518	STAINLESS STEEL LINER KIT

SECTION 5 SCHEMATICS

Section 5 - SCHEMATICS

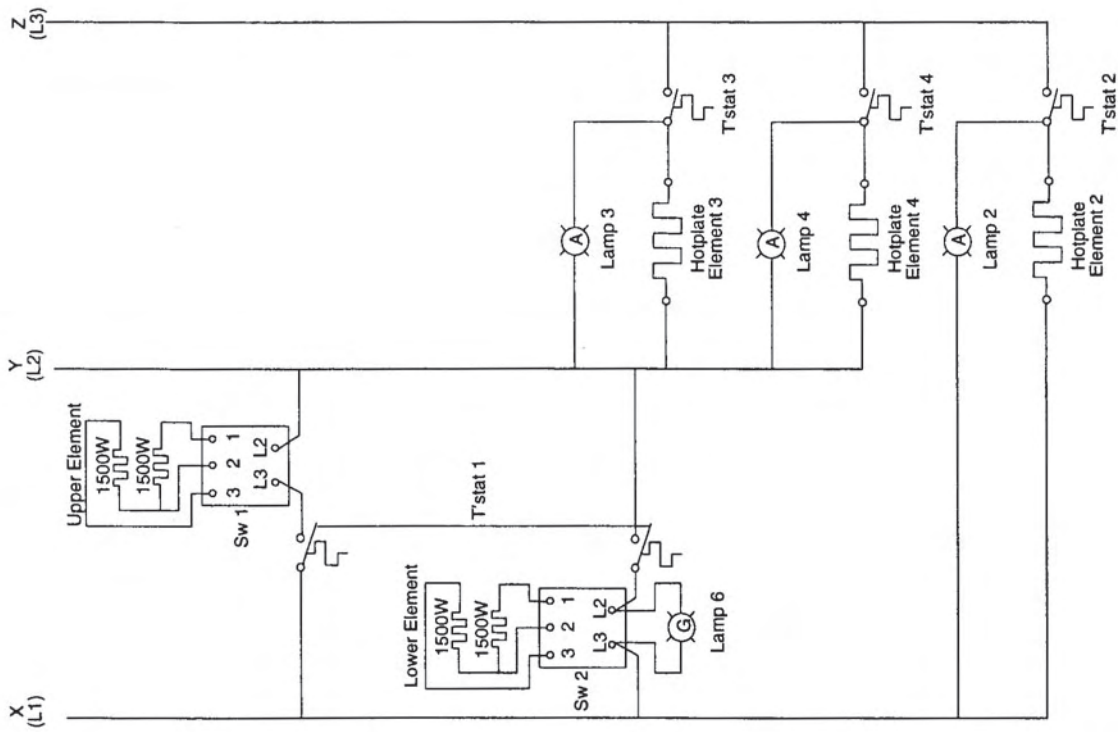

RH36D1 SCHEMATIC
208/240V

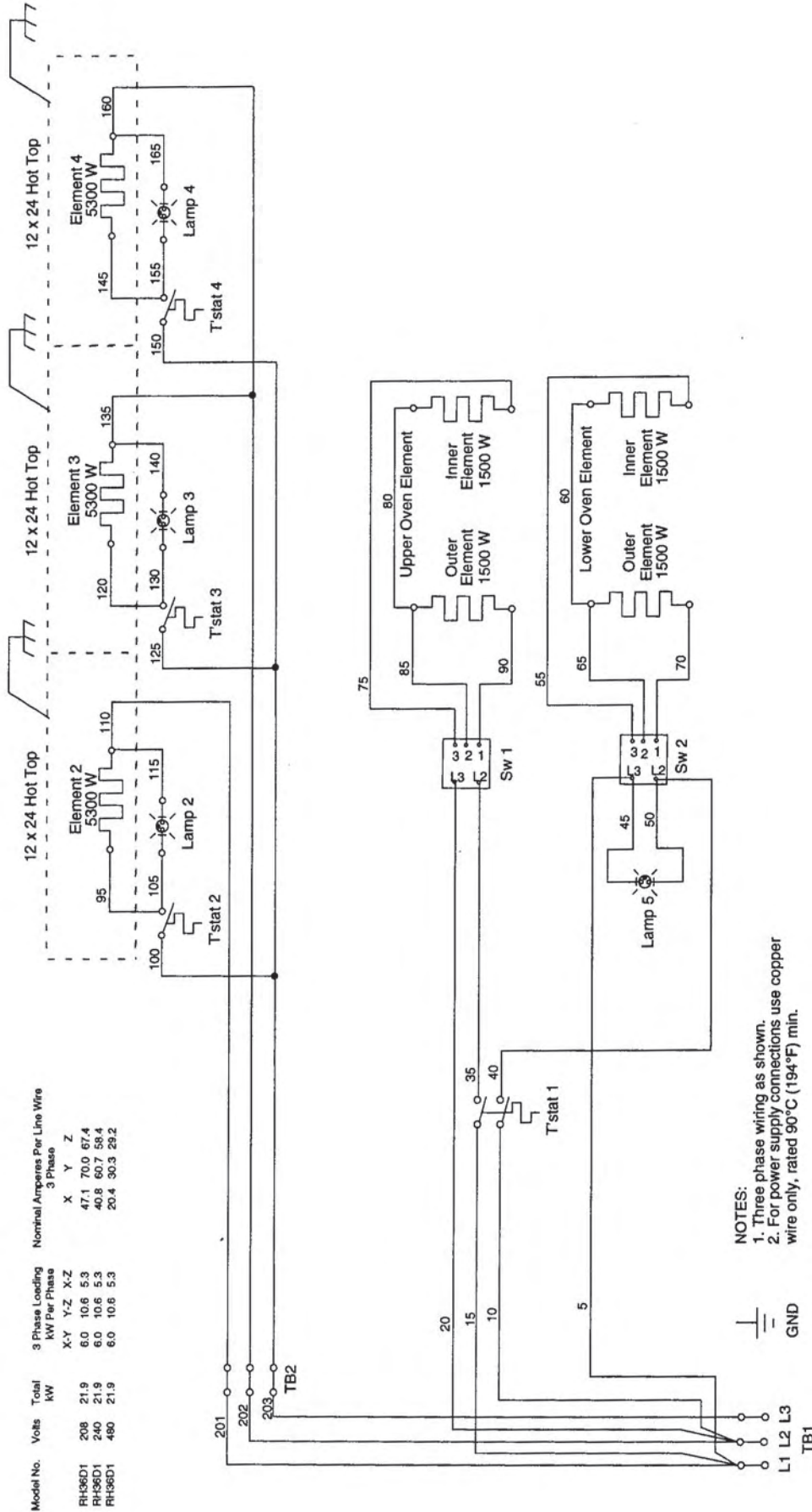

RH36D1 WIRING DIAGRAM
208/240V



Section 5 - SCHEMATICS

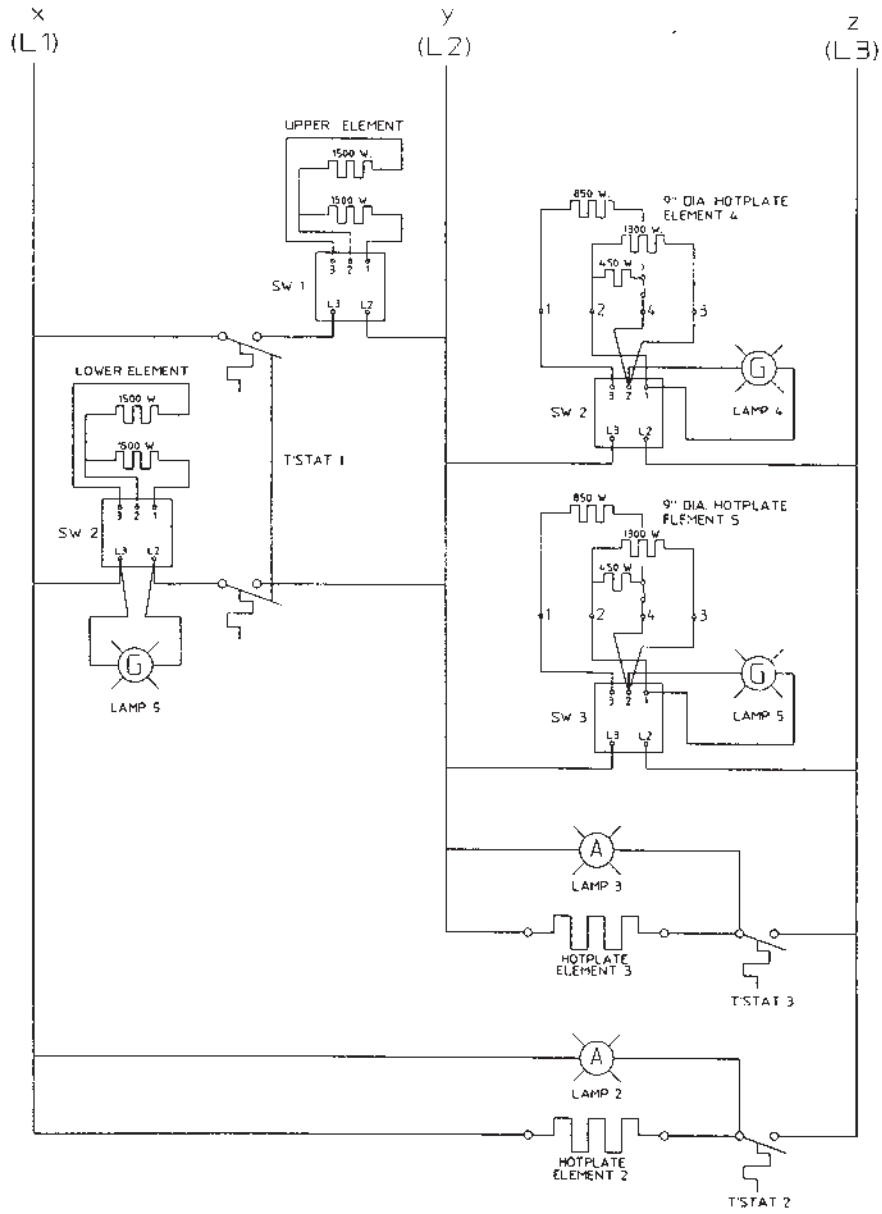

RH36D2 SCHEMATIC
208/240V

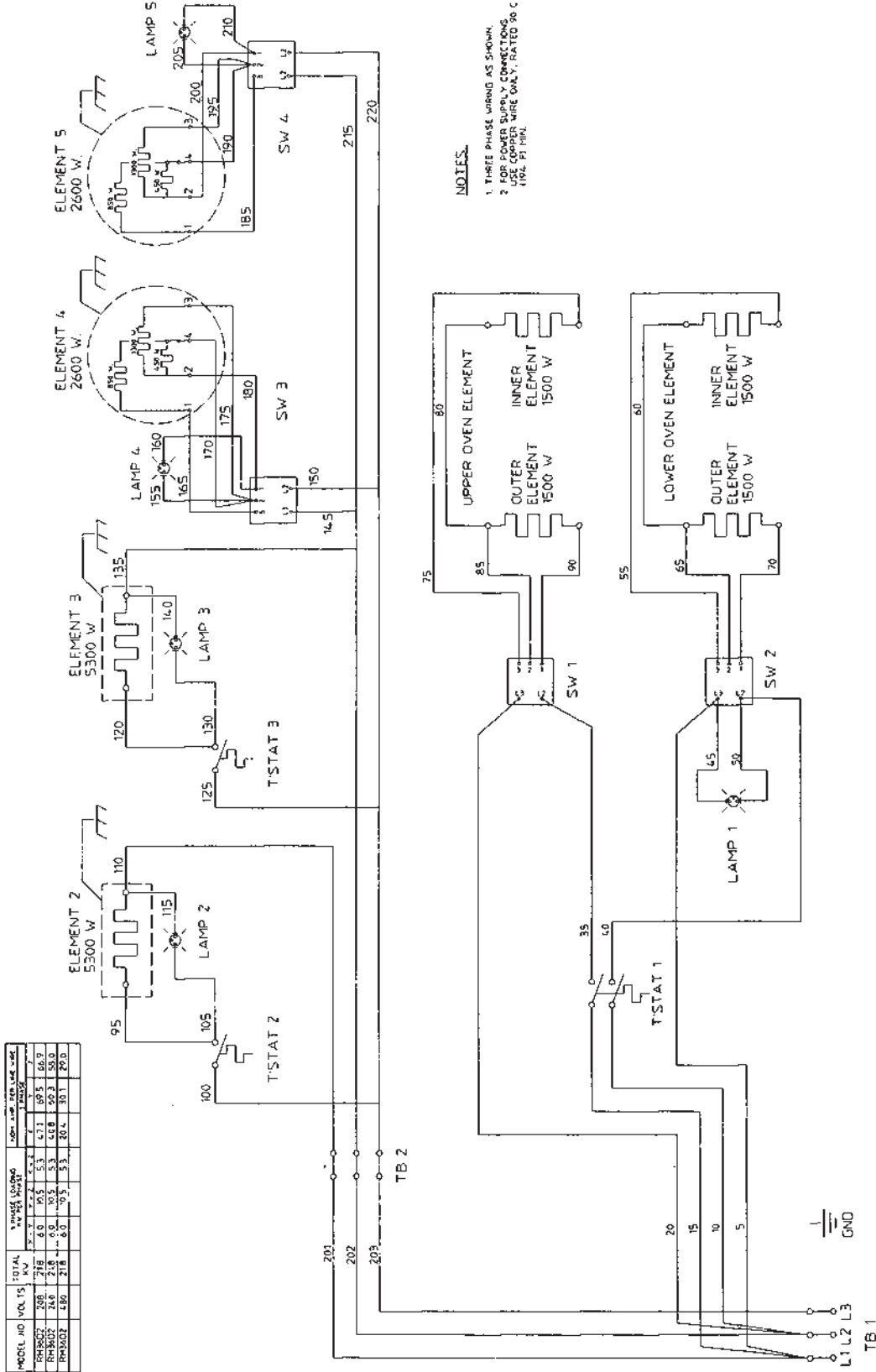

NOTES:
 1. THREE PHASE WIRING AS SHOWN.
 2. FOR POWER SUPPLY CONNECTIONS, USE COPPER WIRE ONLY, RATED 90 C (104 F) MIN.

**RH36D2 WIRING DIAGRAM
 208/240V**

MODEL NO.	VOL TS	TOTAL KW	1 PHASE 120/240V					3 PHASE 208/240V				
			2-2	3-2	4-2	5-2	6-2	2-3	3-3	4-3	5-3	6-3
RH36D2	208	218	6.0	10.5	5.3	4.7	10.5	6.9				
RH36D2	240	218	6.0	10.5	5.3	4.0	10.5	6.9				
RH36D2	208	218	6.0	9.5	5.3	3.9	10.5	6.9				



Section 5 - SCHEMATICS

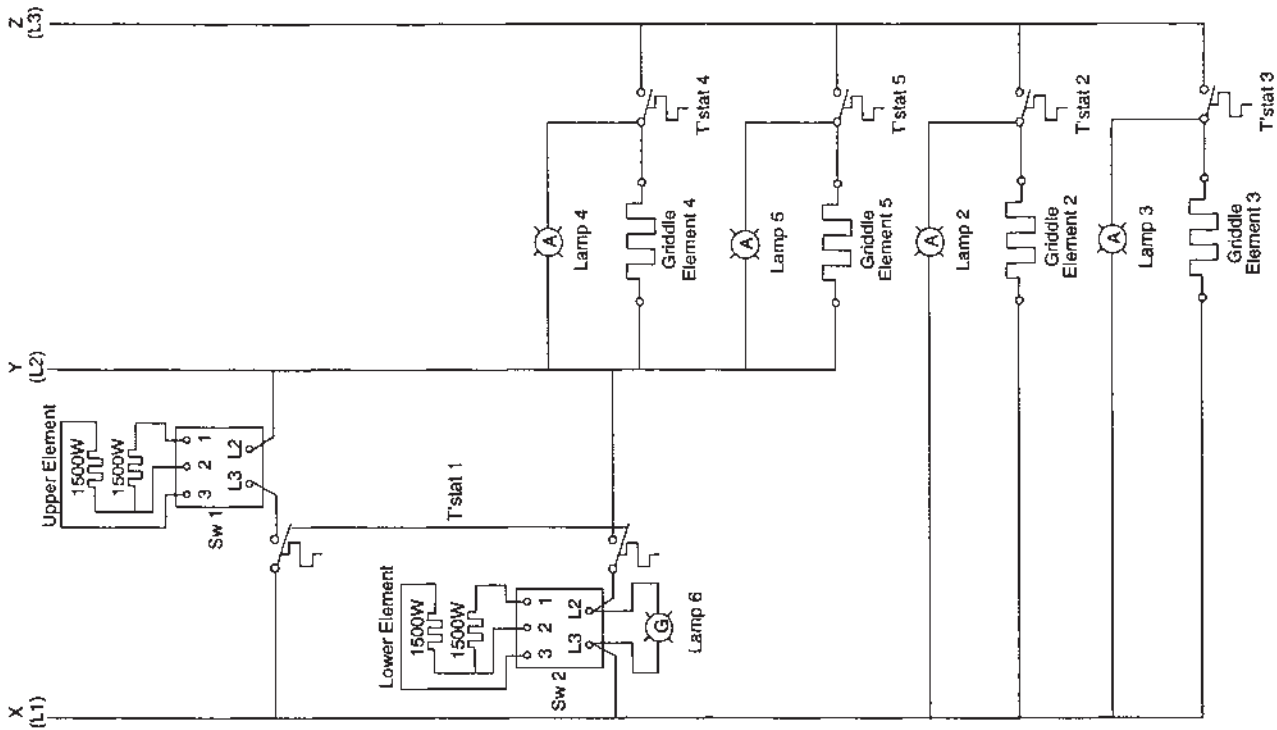

RH36D3 SCHEMATIC
208/240V

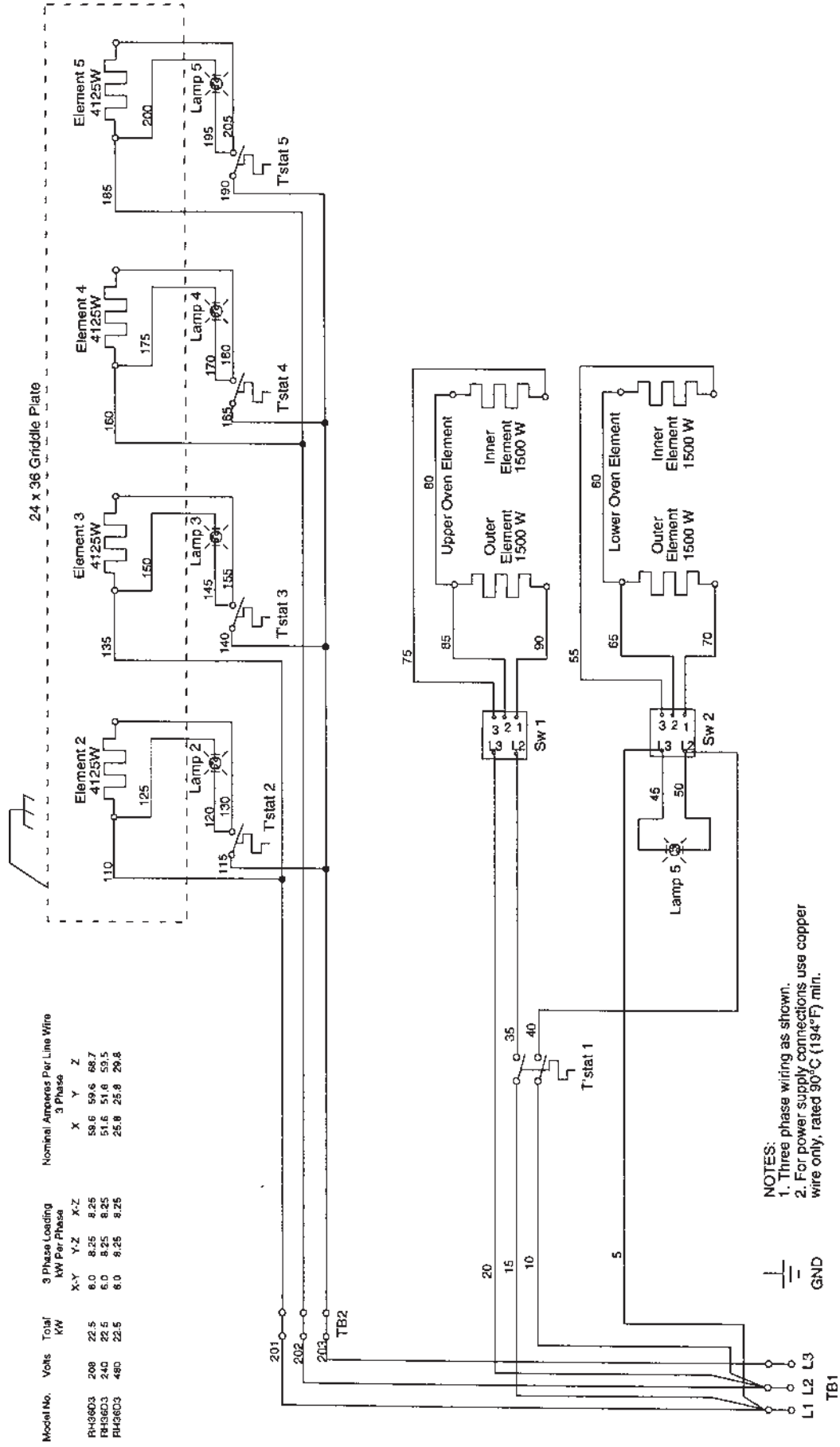

Model No.	Volts	Total kW	3 Phase Loading kW Per Phase			Nominal Amperes Per Line Wire 3 Phase		
			X-Y	Y-Z	X-Z	X	Y	Z
RH36D3	208	22.5	8.0	8.25	8.25	59.6	59.6	68.7
RH36D3	240	22.5	6.0	6.25	6.25	51.6	51.6	59.5
RH36D3	480	22.5	6.0	6.25	6.25	25.8	25.8	29.8

- NOTES:
1. Three phase wiring as shown.
 2. For power supply connections use copper wire only, rated 90°C (194°F) min.

RH36D3 WIRING DIAGRAM
208/240V



Section 5 - SCHEMATICS

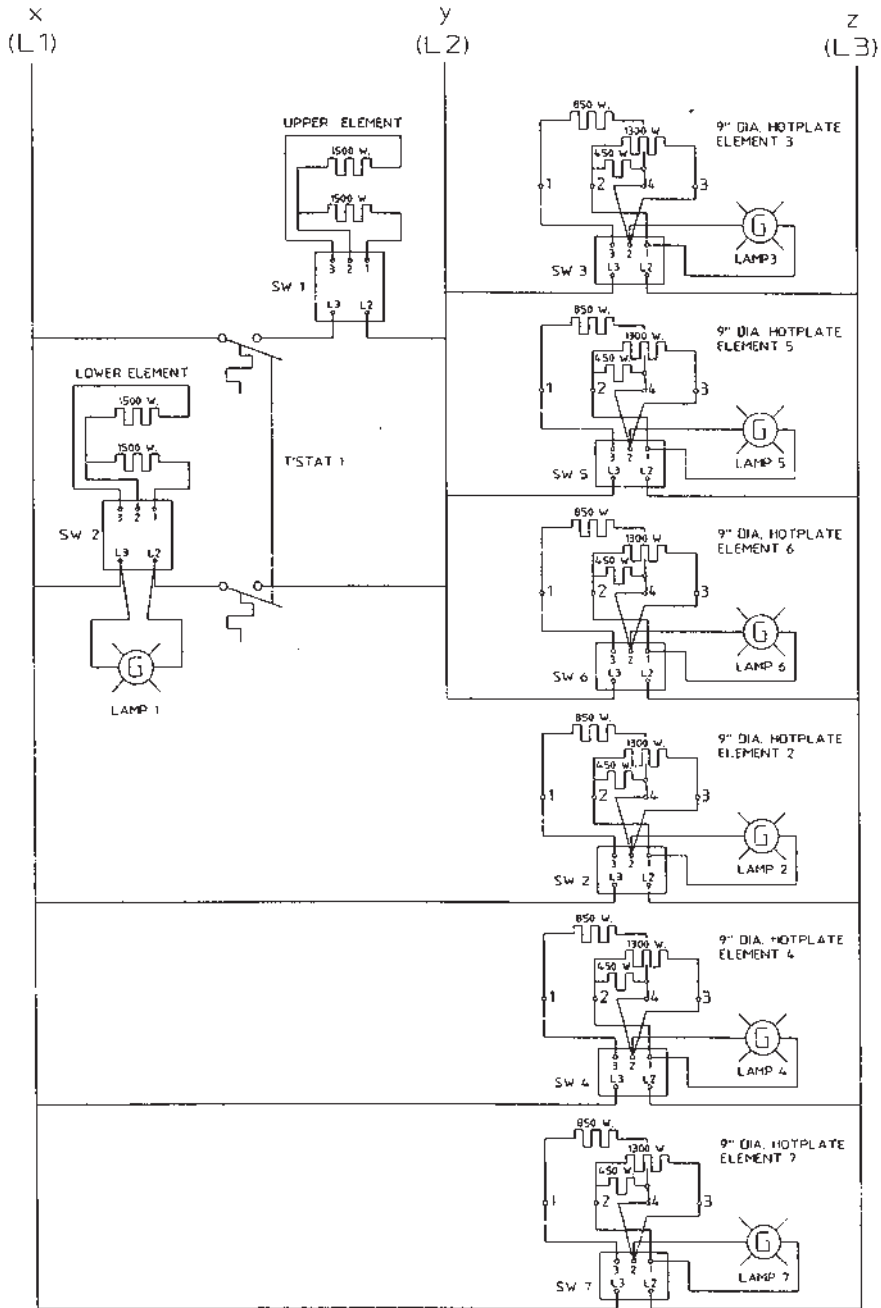

RH36D4 SCHEMATIC
208/240V

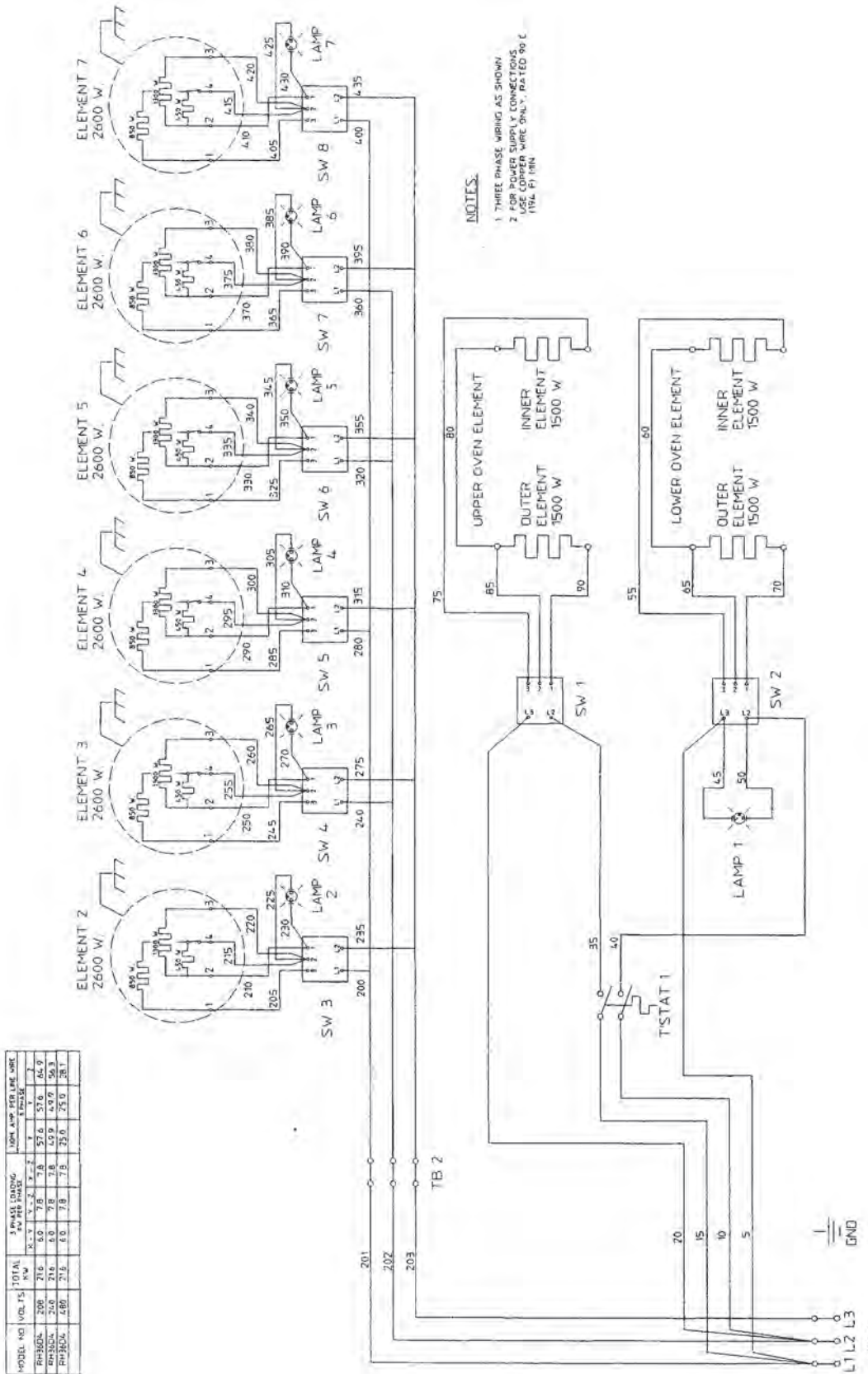

**RH36D4 WIRING DIAGRAM
208/240V**

Section 5 - SCHEMATICS

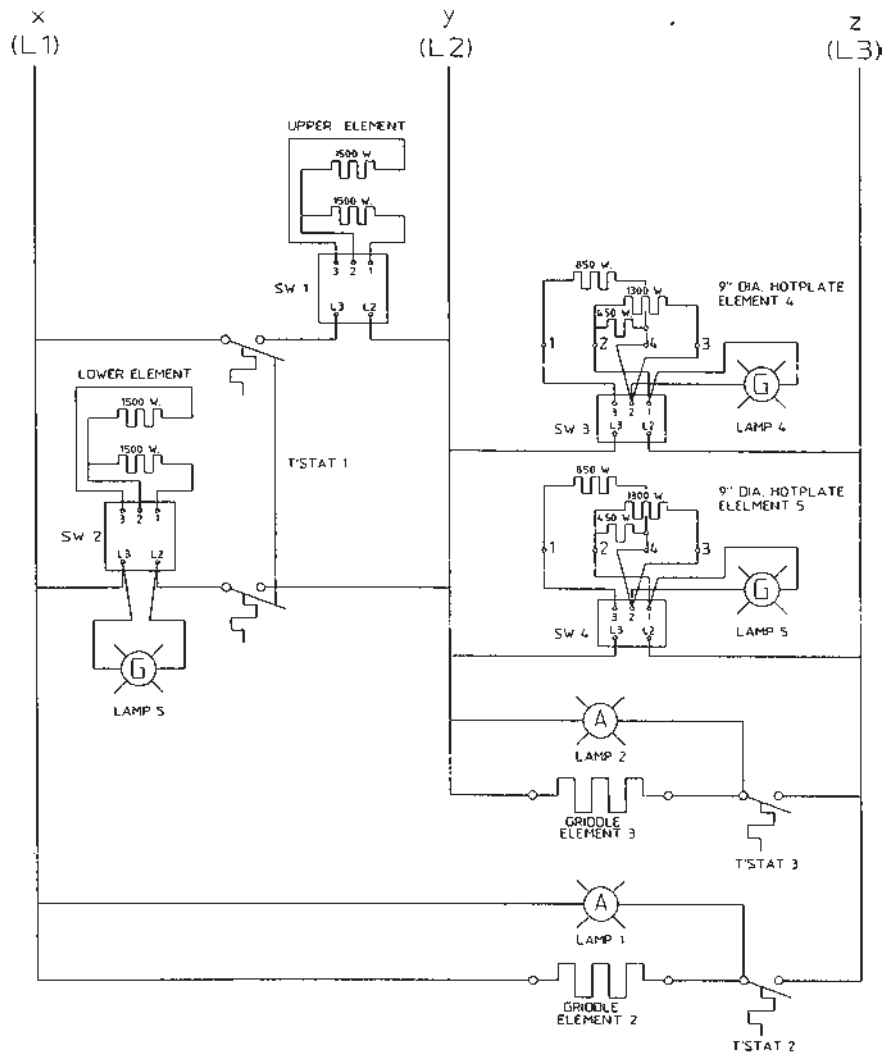

RH36D6 SCHEMATIC
208/240V

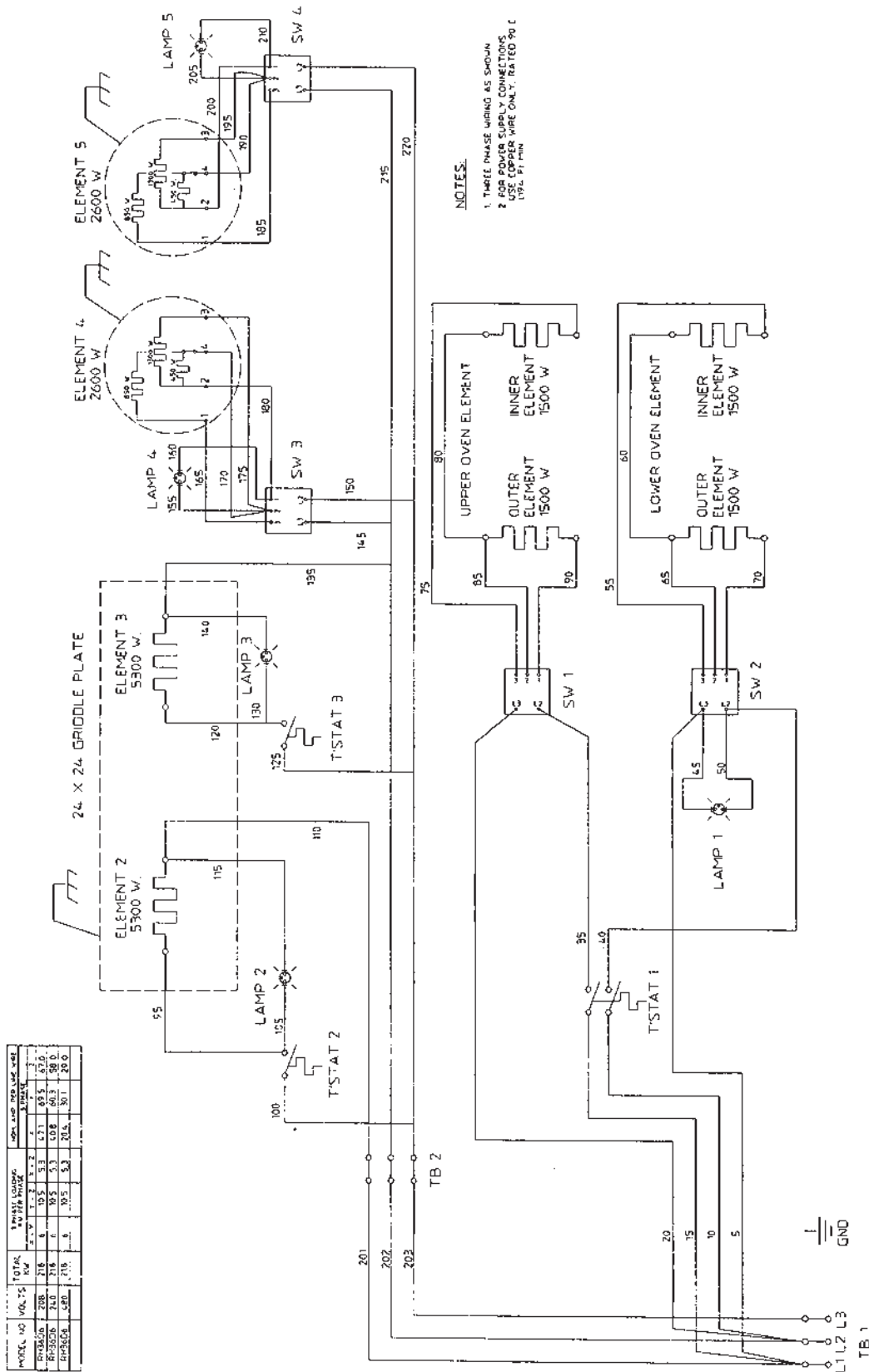

NOTES:
 1. THREE PHASE WIRING AS SHOWN
 2. FOR POWER SUPPLY CONNECTIONS USE COPPER WIRE ONLY, RATED 90 C 192. FT MIN.

RH36D6 WIRING DIAGRAM
 208/240V



Section 5 - SCHEMATICS

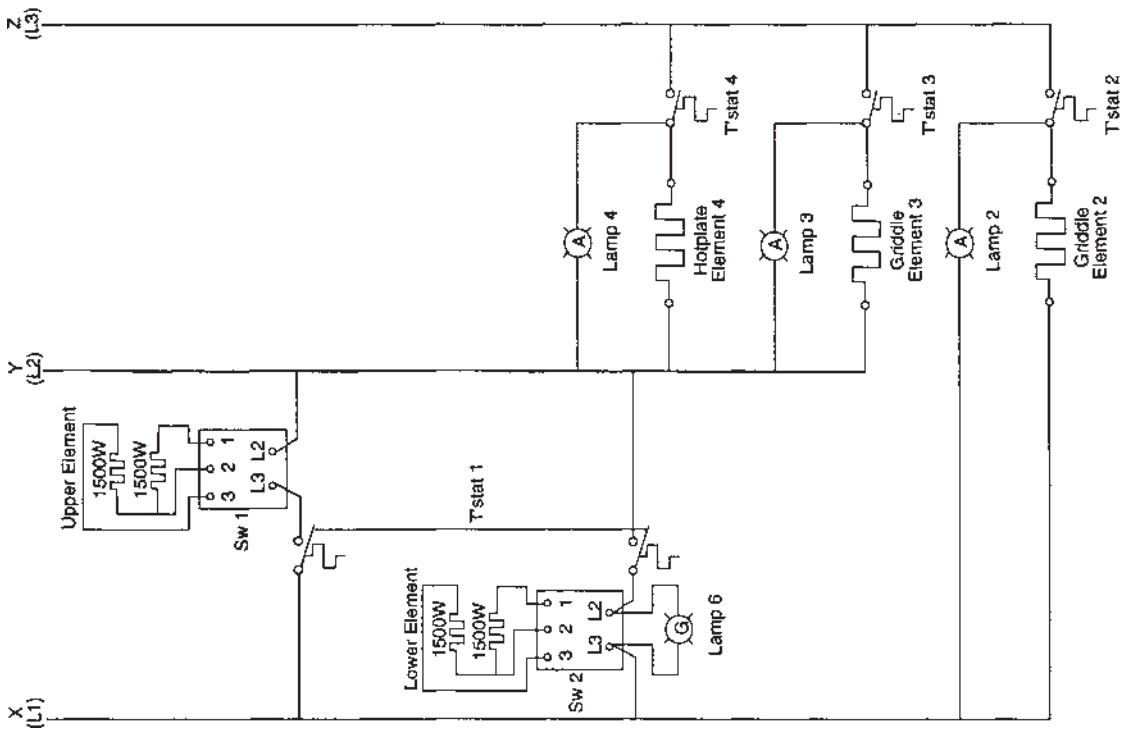

RH36D7 SCHEMATIC
208/240V

Model No.	Volts	Total kW	3 Phase Loading kW Per Phase			Nominal Amperes Per Line Wire 3 Phase		
			X-Y	Y-Z	X-Z	X	Y	Z
RH36D7	208	21.9	6.0	10.6	5.3	47.1	70.0	67.4
RH36D7	240	21.9	6.0	10.6	5.3	40.8	60.7	58.4
RH36D7	480	21.9	6.0	10.6	5.3	20.4	30.3	29.2

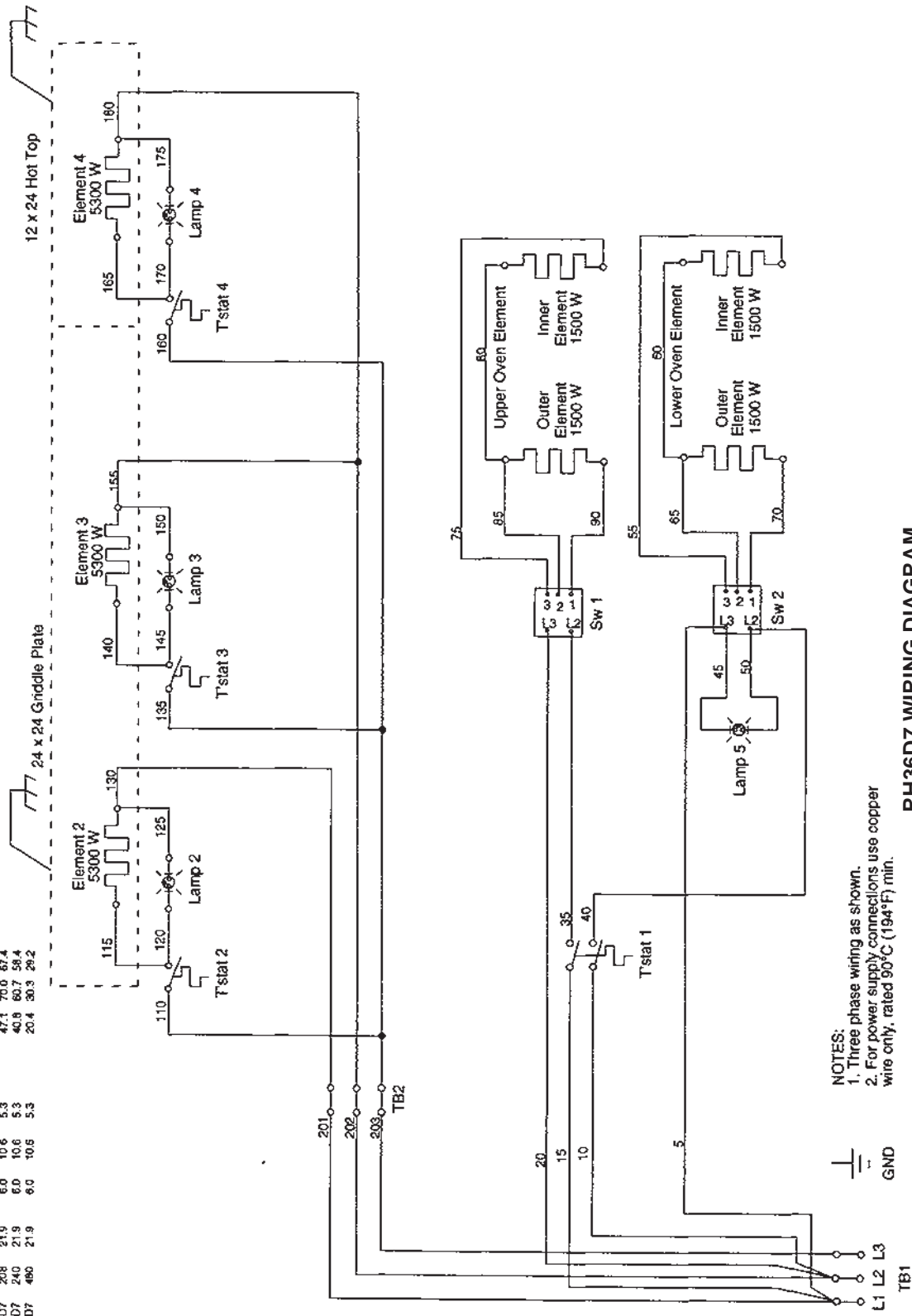

NOTES:
 1. Three phase wiring as shown.
 2. For power supply connections use copper wire only, rated 90°C (194°F) min.

RH36D7 WIRING DIAGRAM
208/240V



Section 5 - SCHEMATICS

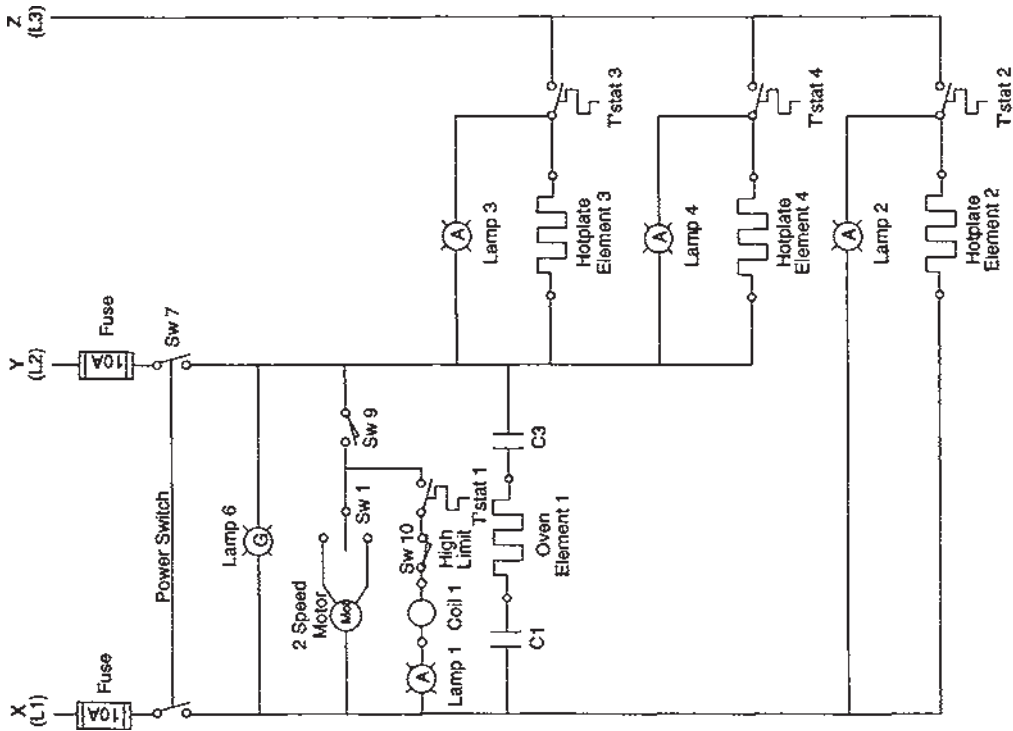

RH36C1 SCHEMATIC
208/240V



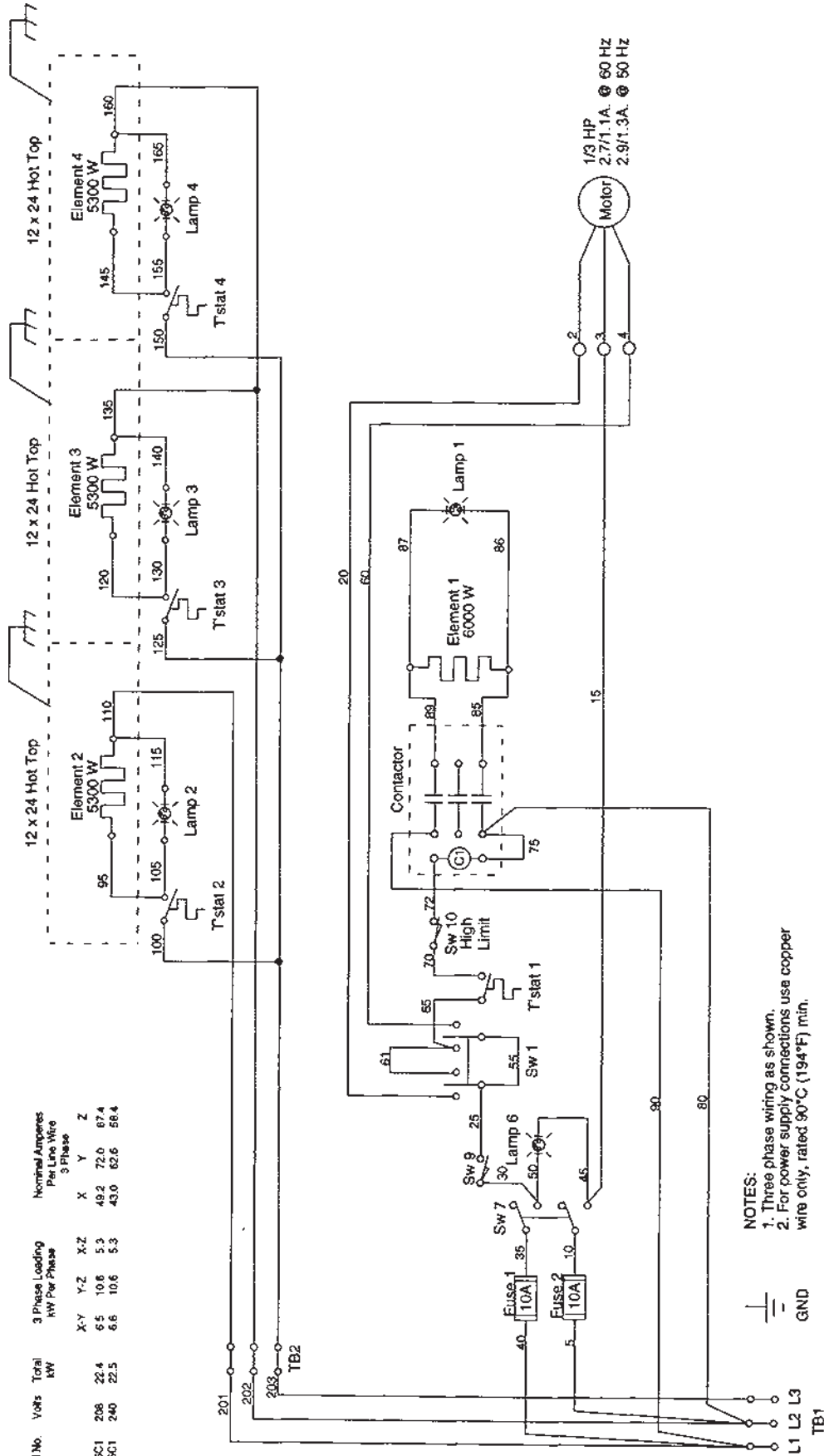

RH36C1 WIRING DIAGRAM
208/240V

NOTES:
1. Three phase wiring as shown.
2. For power supply connections use copper wire only, rated 90°C (194°F) min.

GND

Model No.	Volts	Total kW	3 Phase Loading kW Per Phase			Normal Amperes Per Line Wire 3 Phase		
			X-Y	Y-Z	X-Z	X	Y	Z
RH36C1	208	22.4	6.5	10.6	5.3	49.2	72.0	67.4
MH36C1	240	25.5	6.6	10.6	5.3	43.0	62.6	58.4



Section 5 - SCHEMATICS

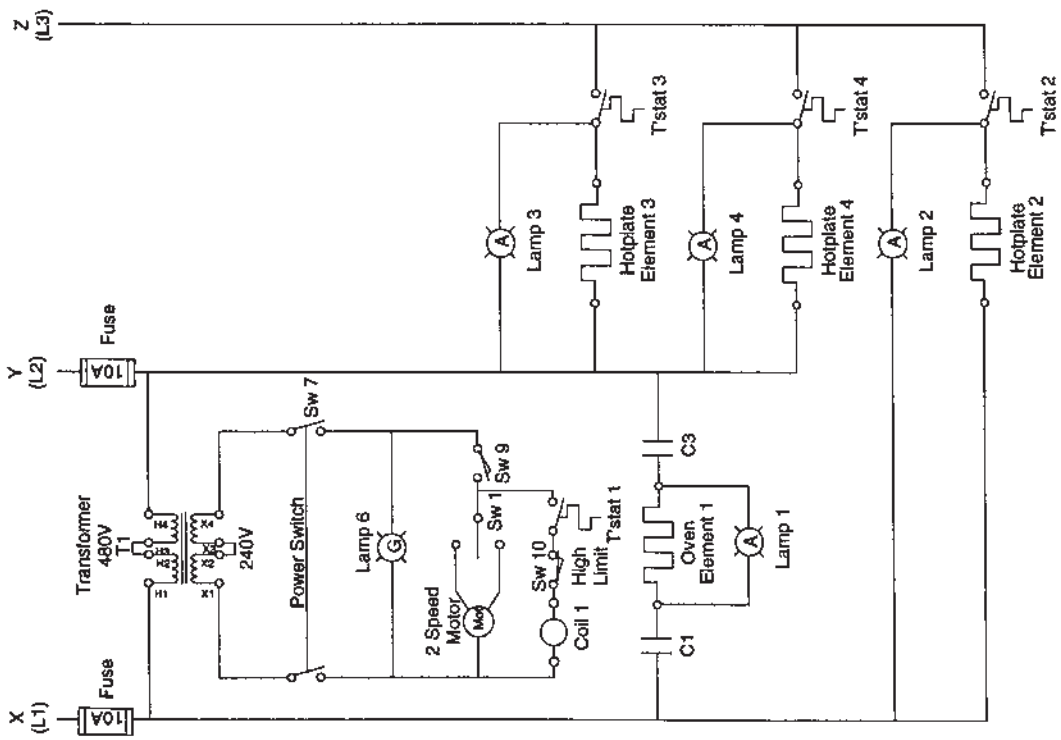

**RH3621 SCHEMATIC
480V**



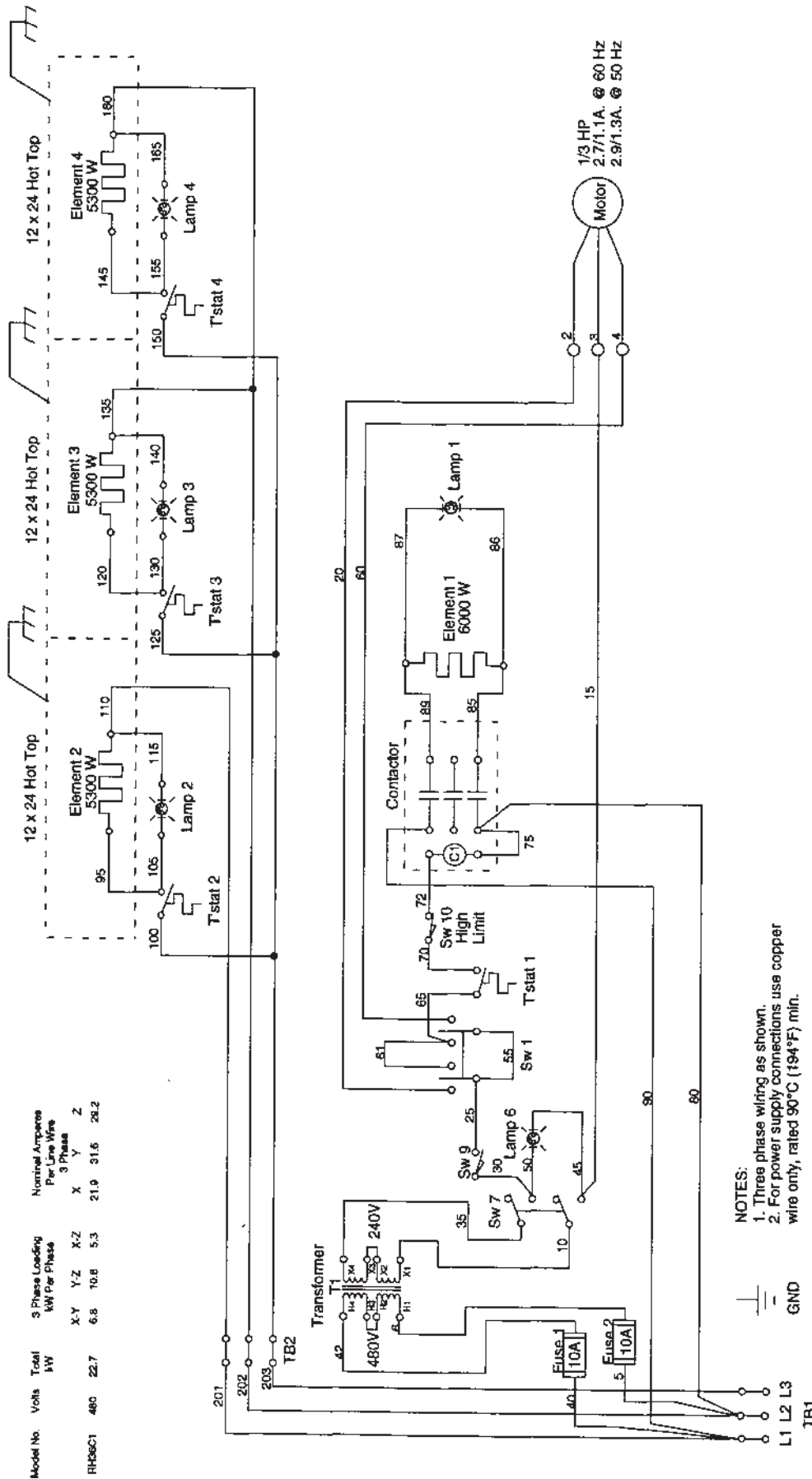

RH36C2 WIRING DIAGRAM
480V



Section 5 - SCHEMATICS

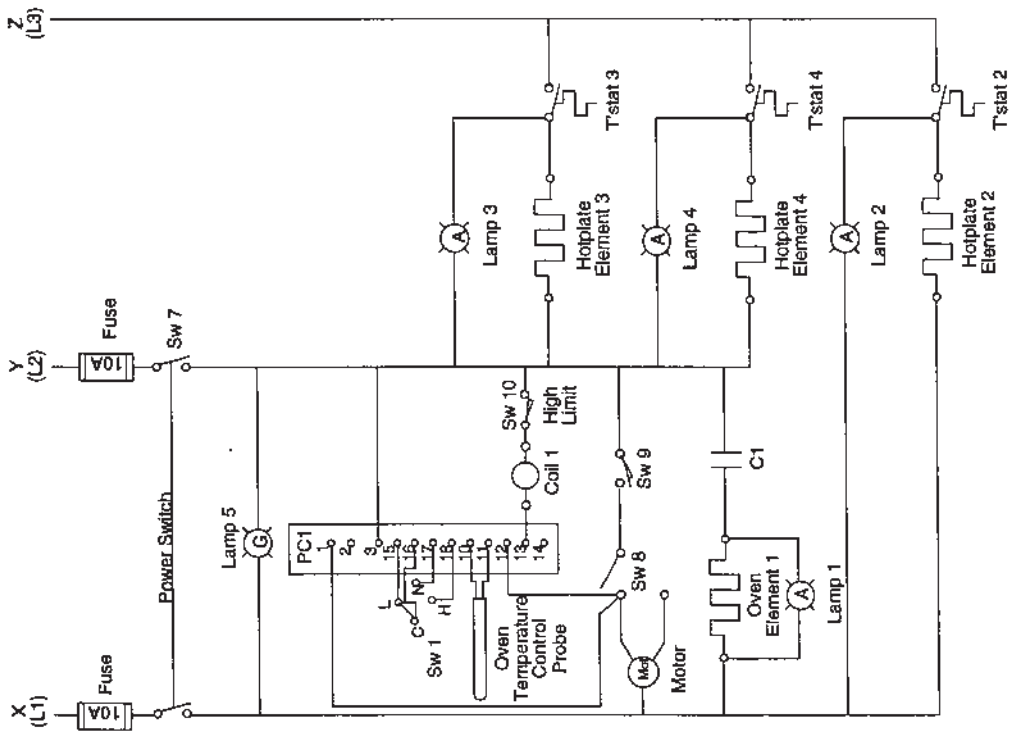

**RH36C1W SCHEMATIC
208/240V**

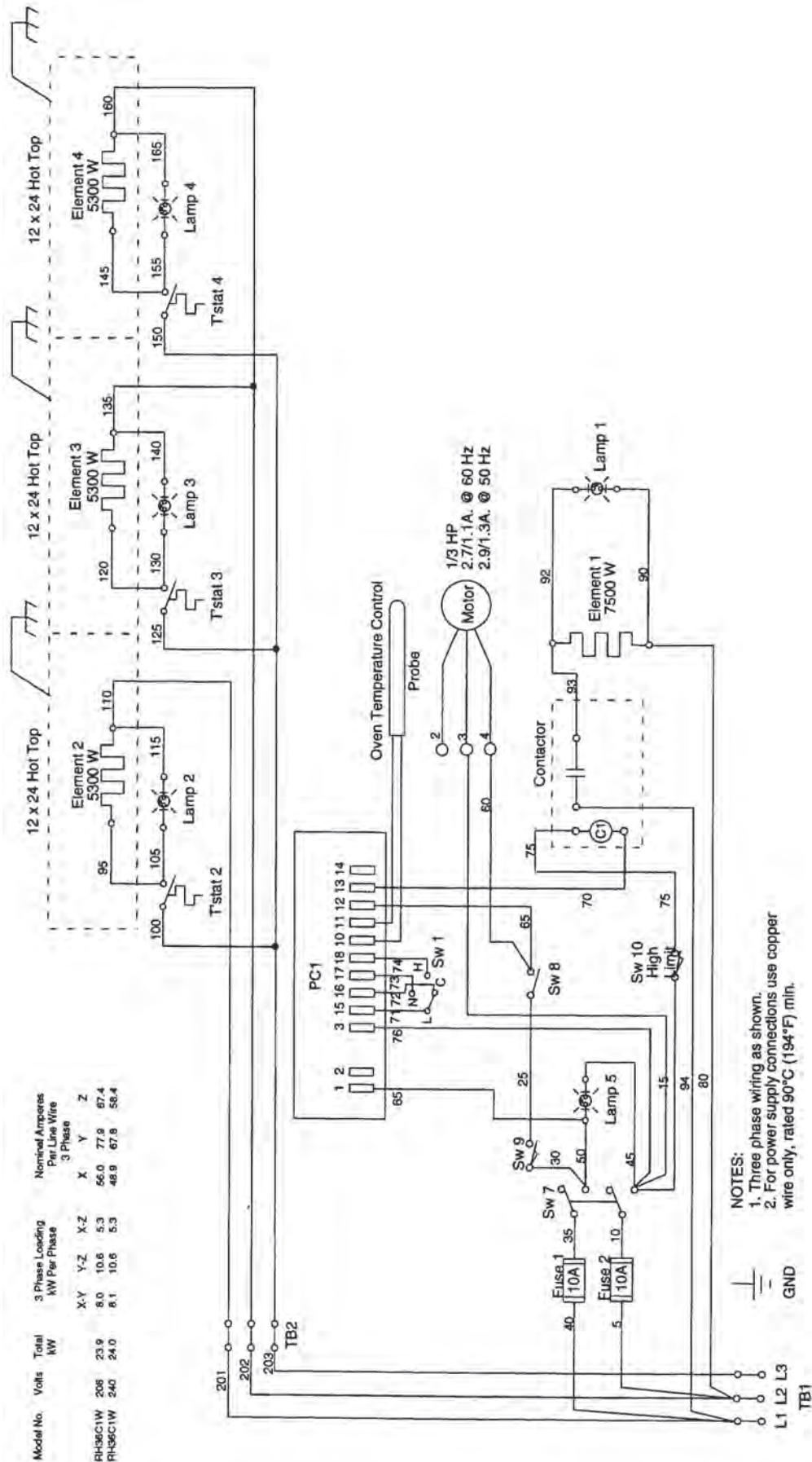

Model No.	Volts	Total KW	3 Phase Loading KW Per Phase			Nominal Amperes Per Line Wire 3 Phase		
			X-Y	Y-Z	X-Z	X	Y	Z
RH36C1W	208	23.9	8.0	10.6	5.3	56.0	77.9	67.4
RH36C1W	240	24.0	8.1	10.6	5.3	48.9	67.8	56.4

- NOTES:
1. Three phase wiring as shown.
 2. For power supply connections use copper wire only, rated 90°C (194°F) min.



RH36C1W WIRING DIAGRAM
208/240V

Section 5 - SCHEMATICS

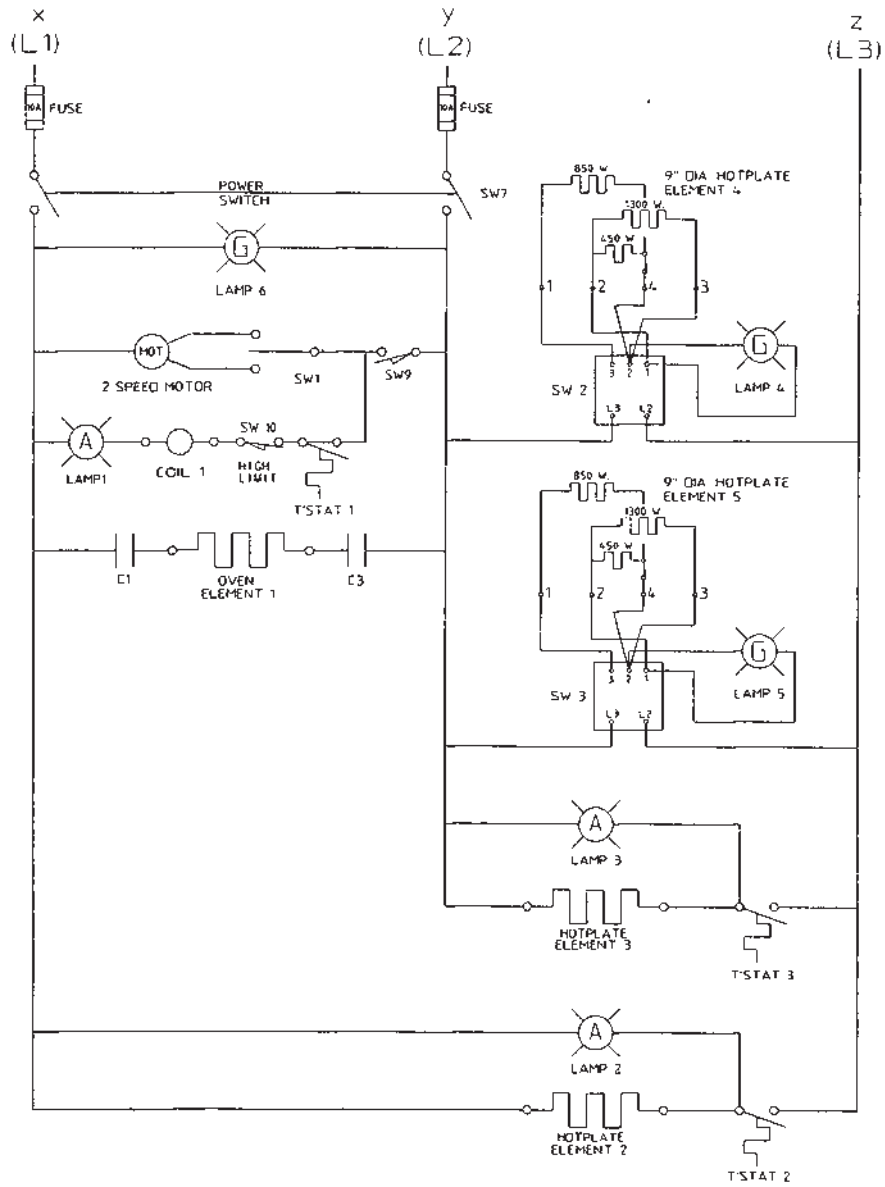

RH36C2 SCHEMATIC
208/240V

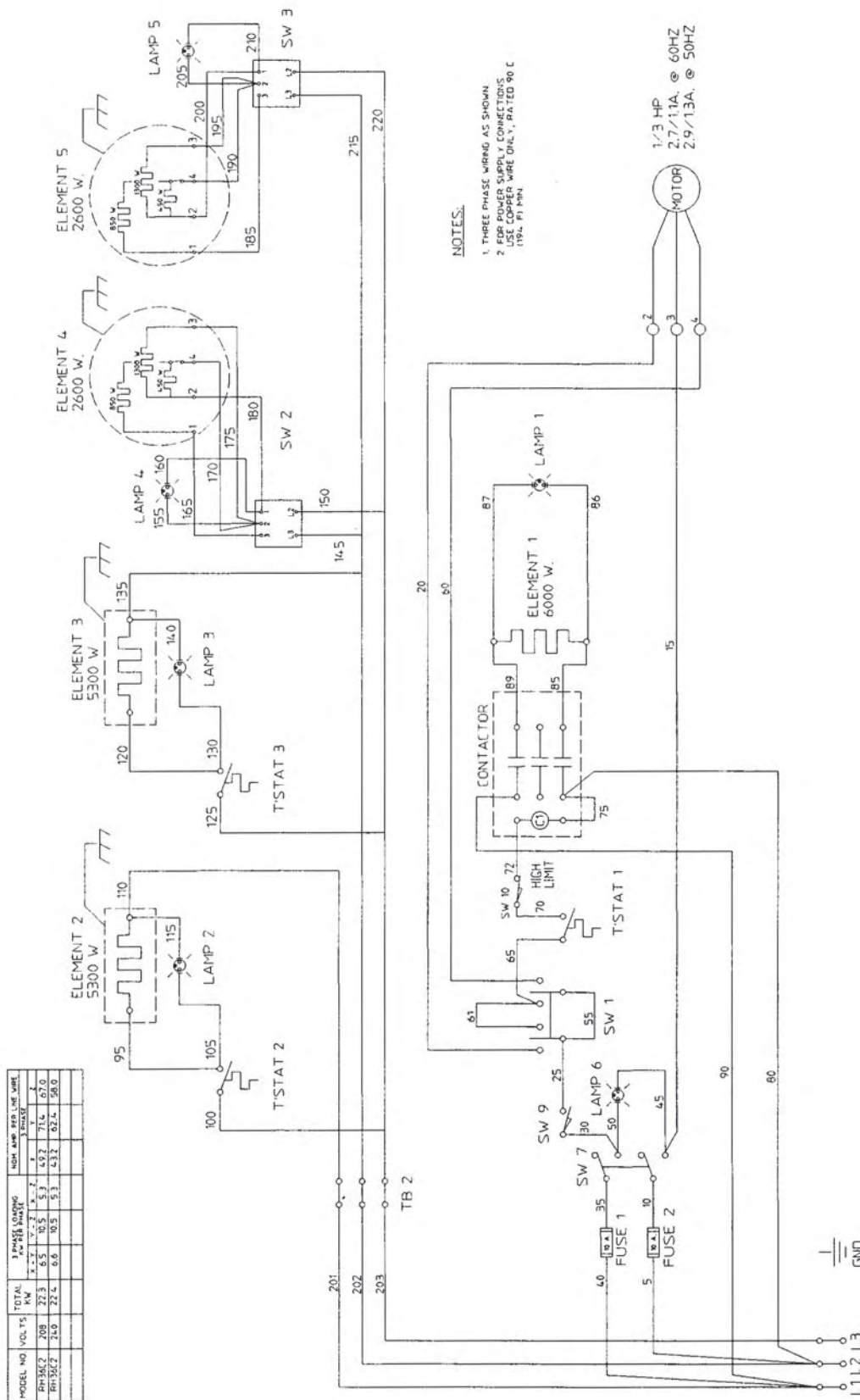

**RH36C2 WIRING DIAGRAM
208/240V**

Section 5 - SCHEMATICS

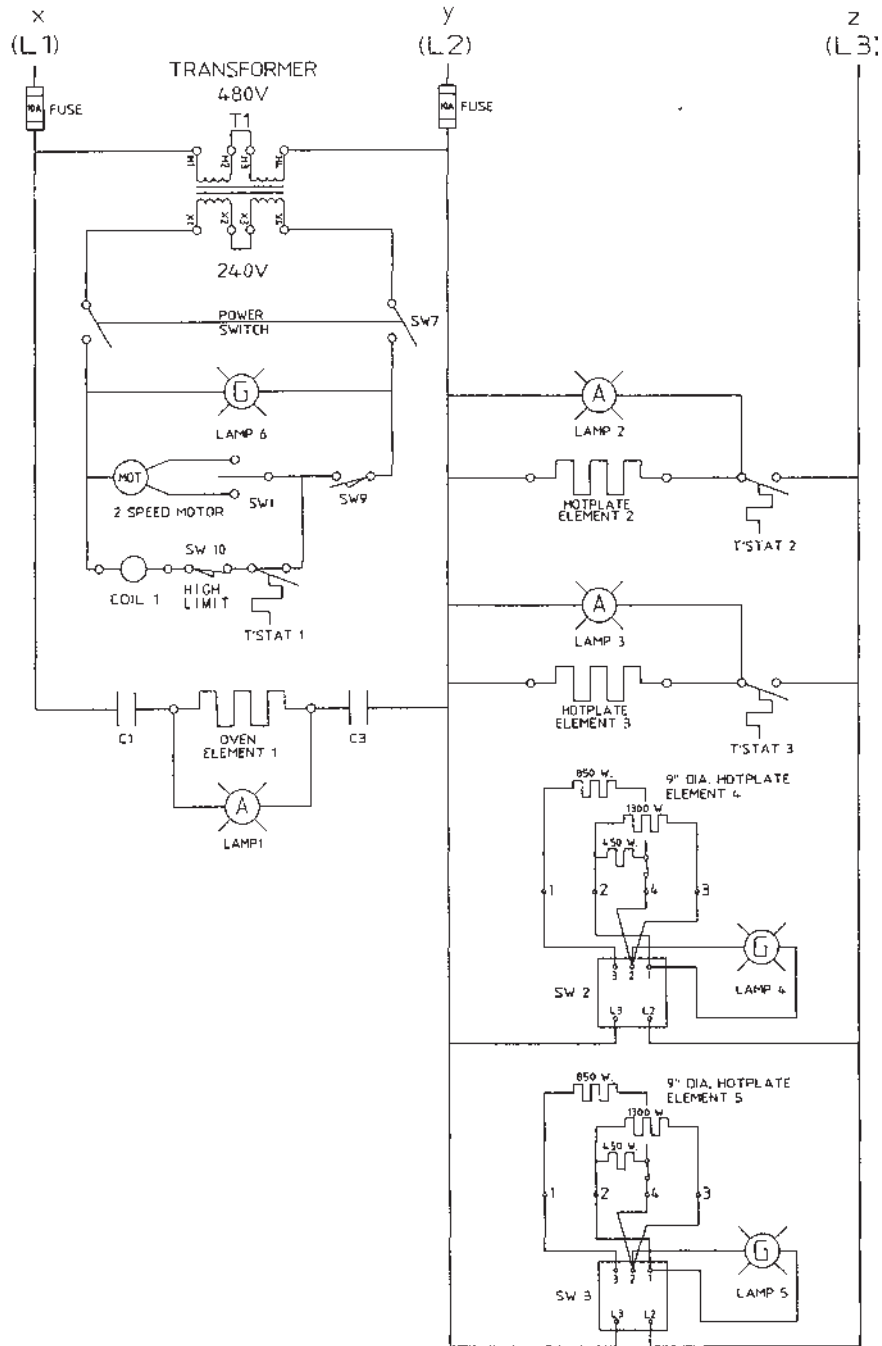

**RH36C2 SCHEMATIC
480V**

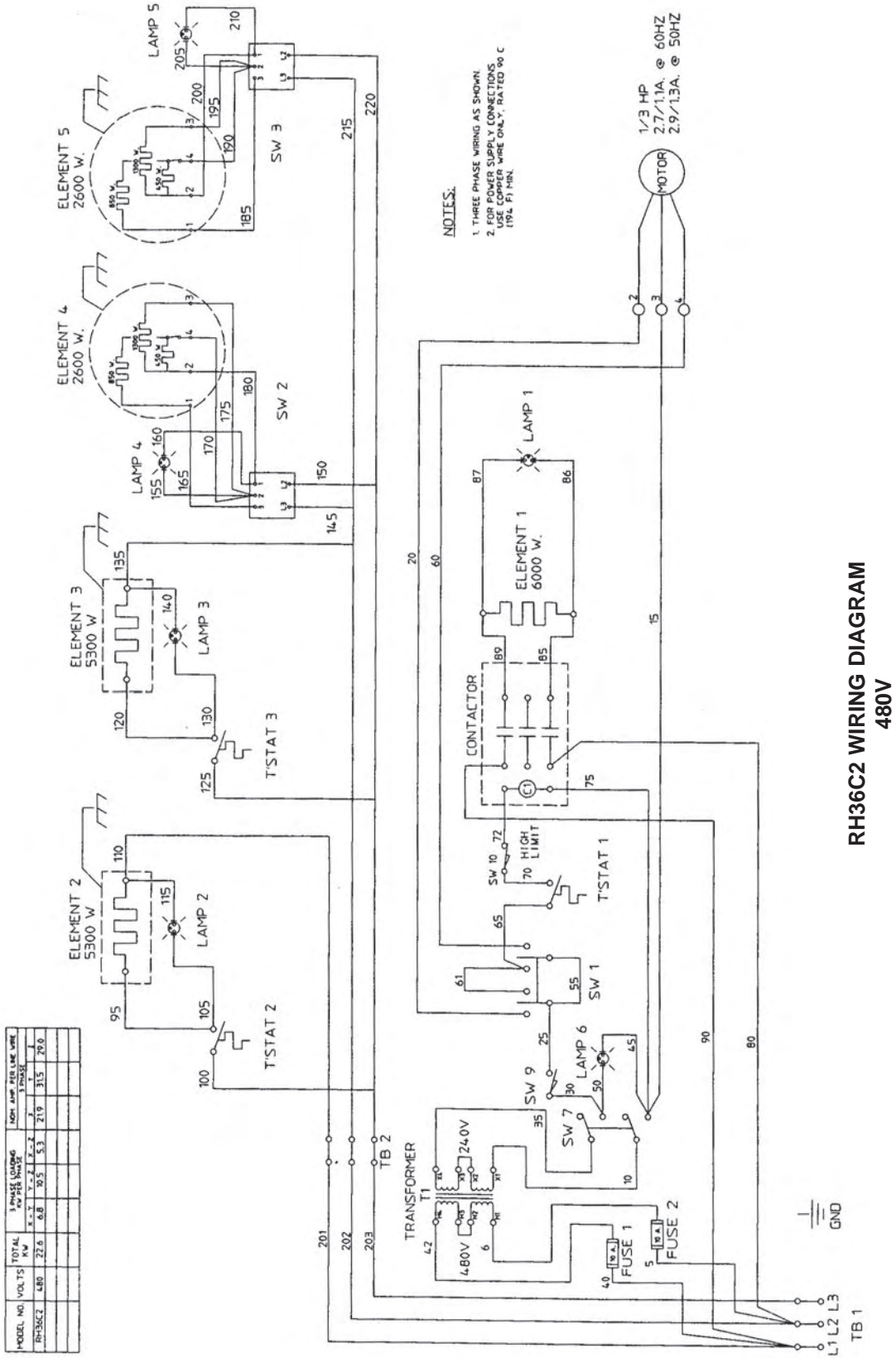

RH36C2 WIRING DIAGRAM
480V



Section 5 - SCHEMATICS

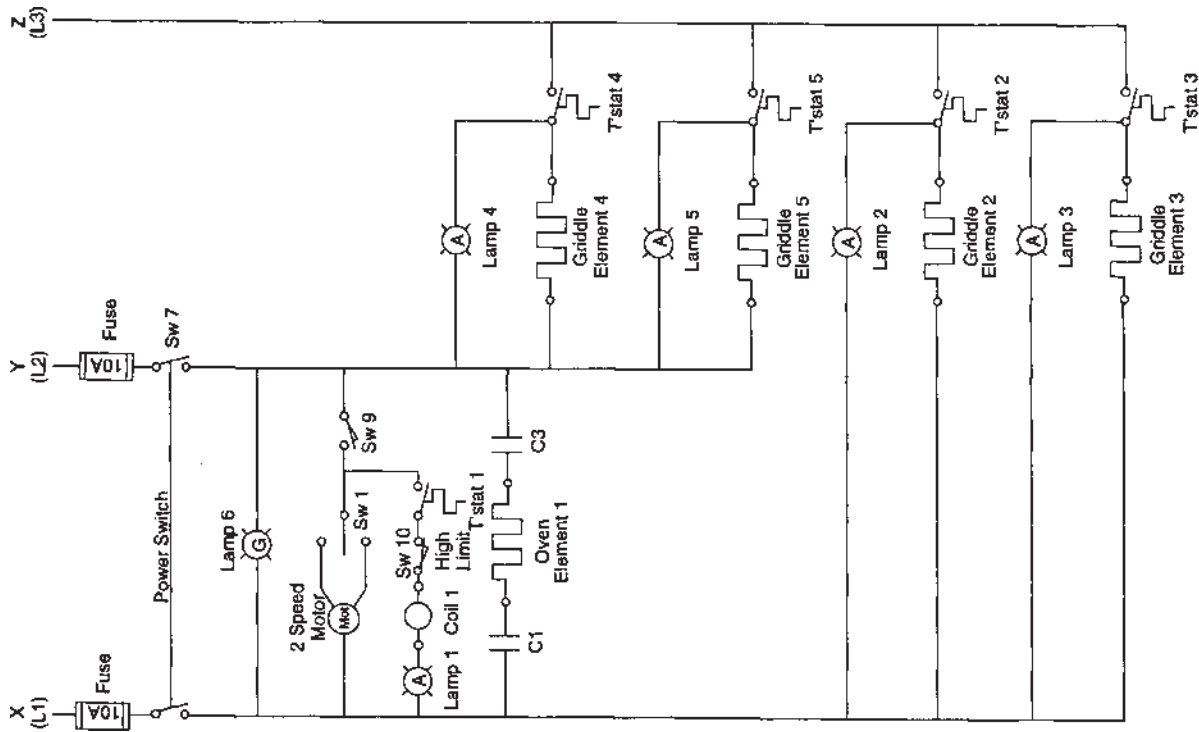

RH36C3 SCHEMATIC
208/240V

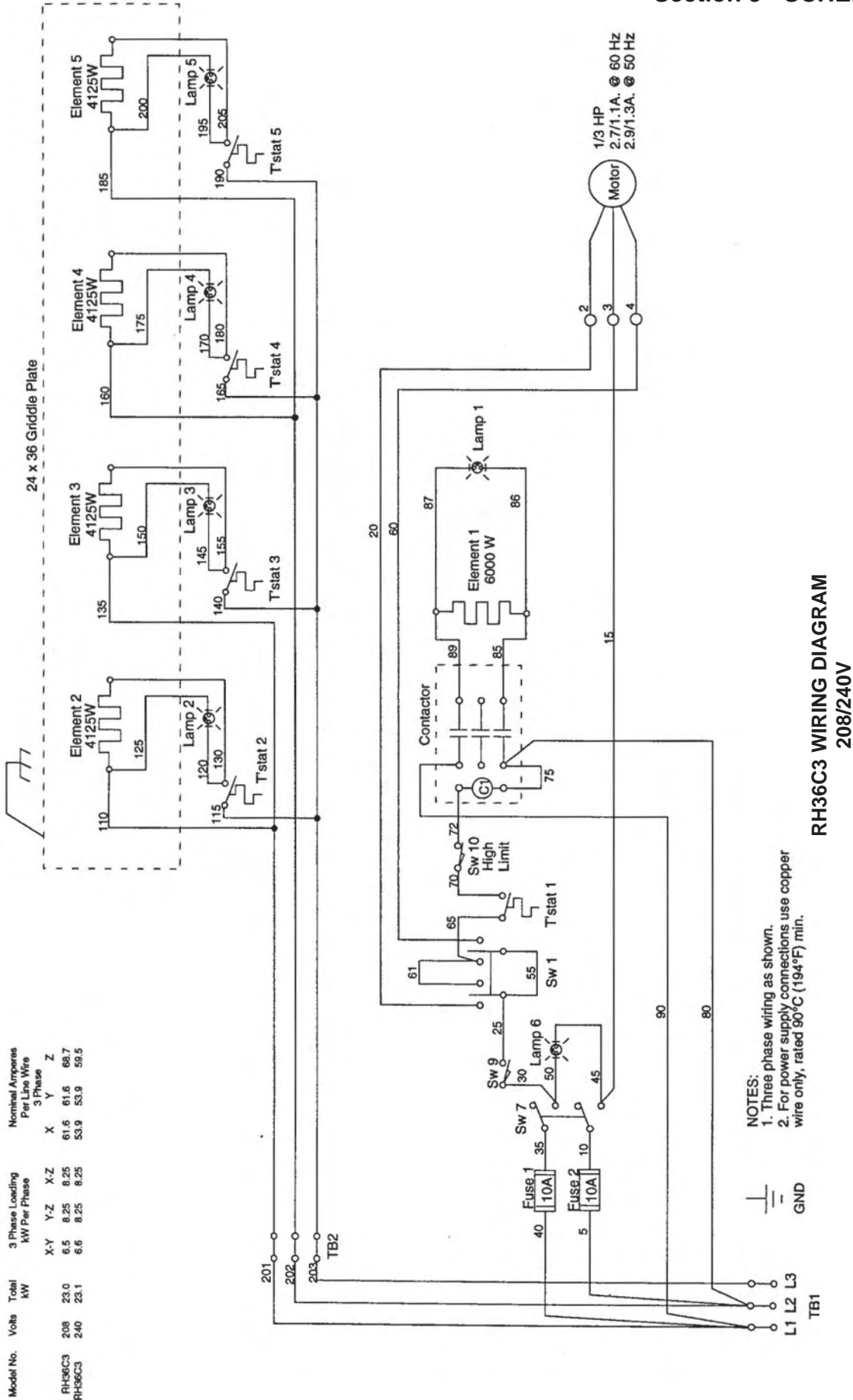

RH36C3 WIRING DIAGRAM
208/240V



Section 5 - SCHEMATICS

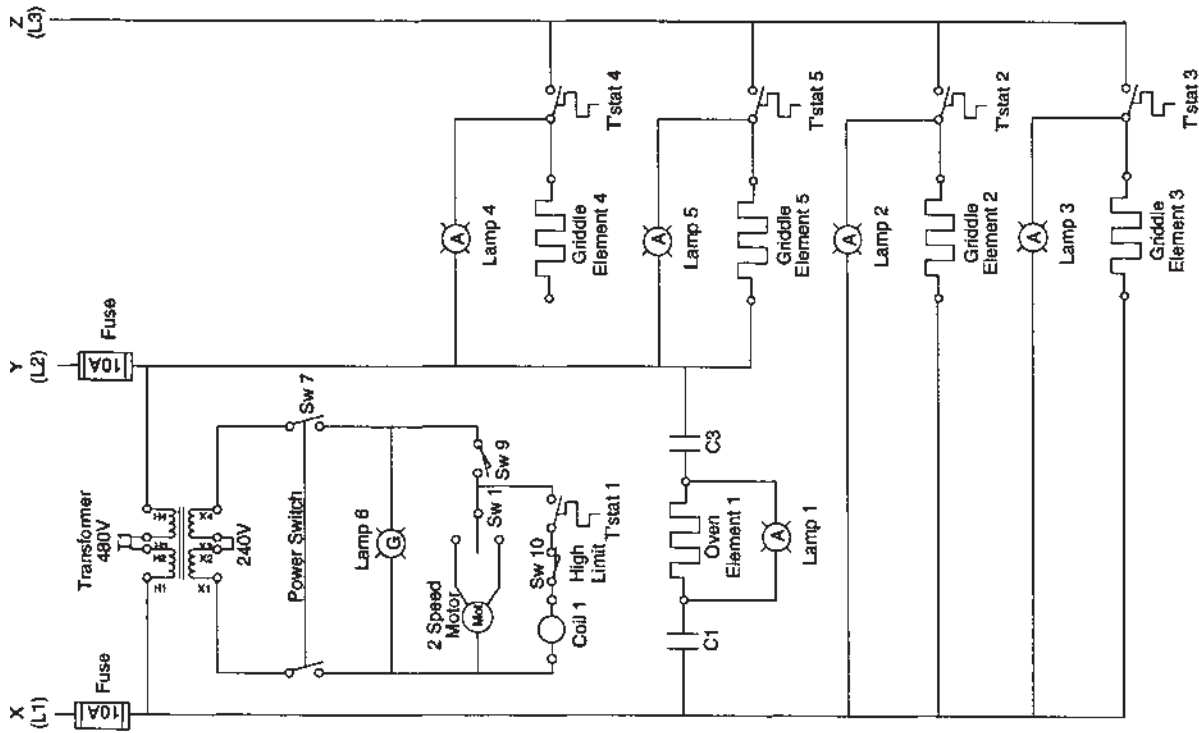

RH36C3 SCHEMATIC
480V

Model No.	Volts	Total kW	3 Phase Loading kW Per Phase			Nominal Amperes Per Line Wire 3 Phase		
			X-Y	Y-Z	X-Z	X	Y	Z
RH36C3	480	22.4	6.8	7.8	7.8	28.4	28.4	28.1

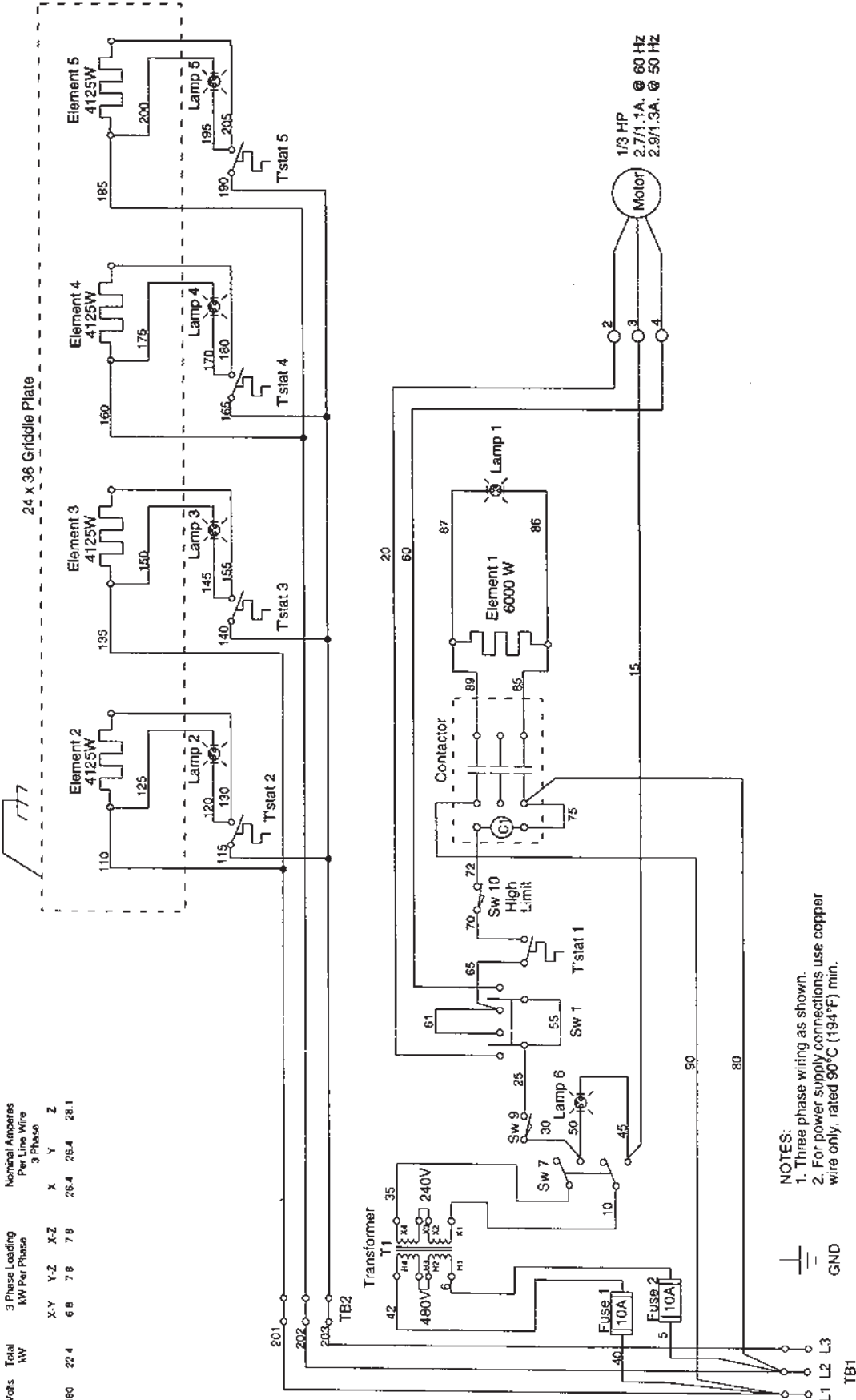

- NOTES:
1. Three phase wiring as shown.
 2. For power supply connections use copper wire only, rated 90°C (194°F) min.

RH36C3 WIRING DIAGRAM
480V

Section 5 - SCHEMATICS

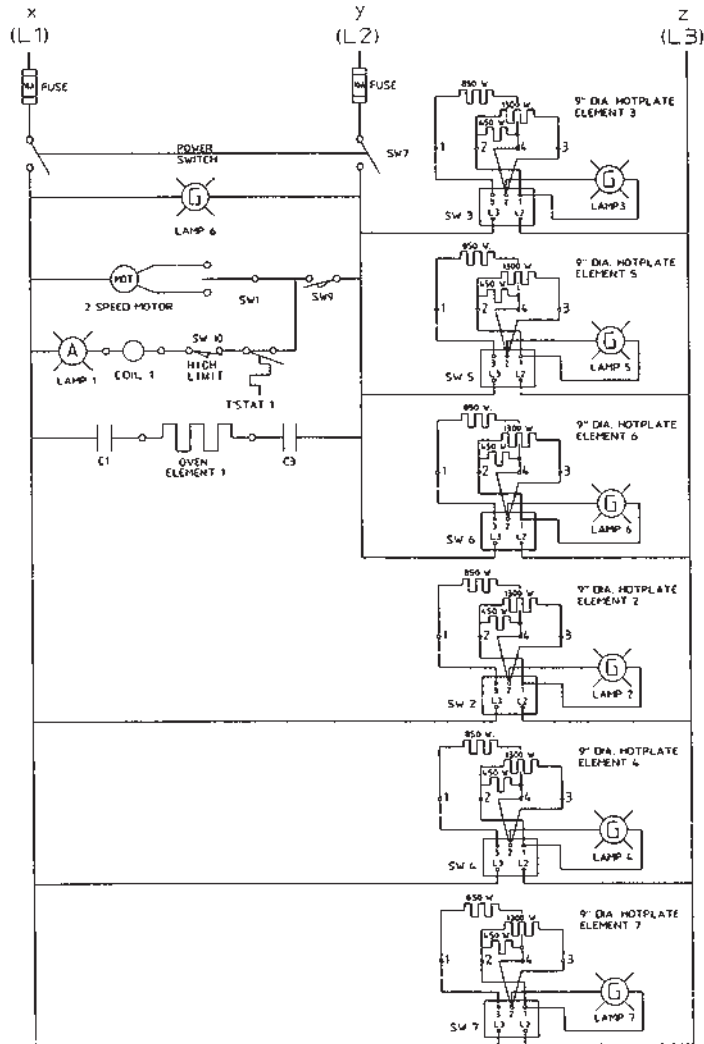

RH36C4 SCHEMATIC
208/240V

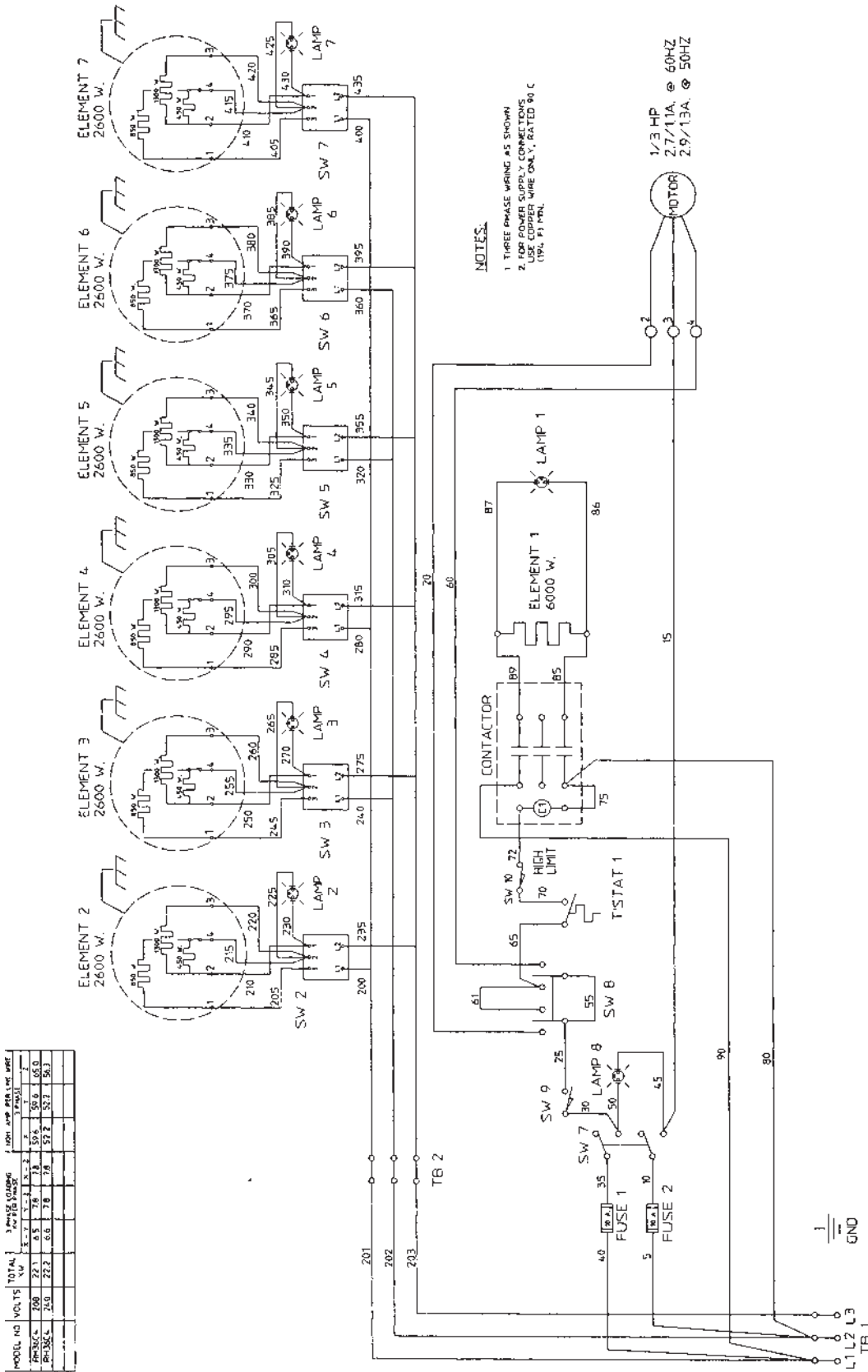

RH36C4 WIRING DIAGRAM
208/240V



Section 5 - SCHEMATICS

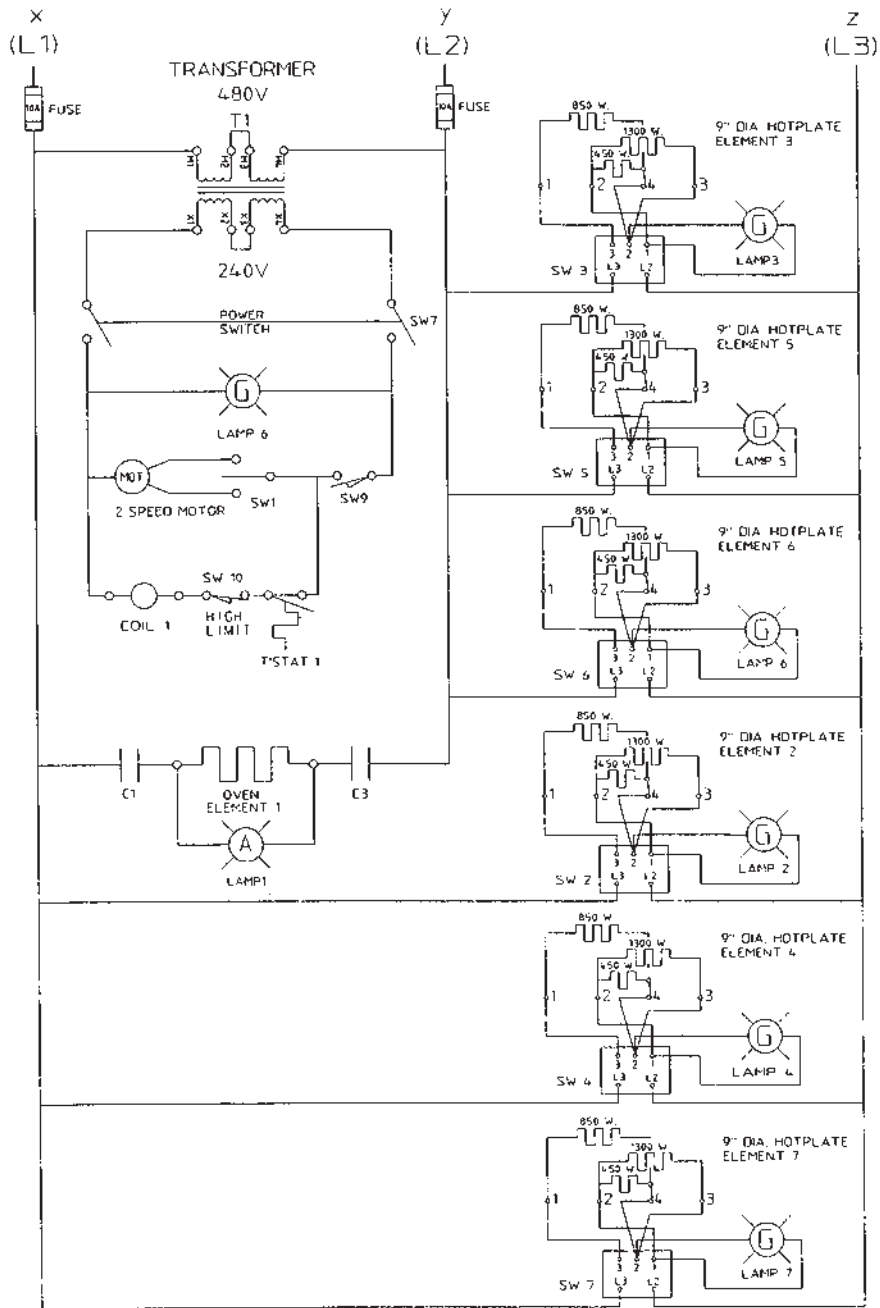

RH36C4 SCHEMATIC
480V

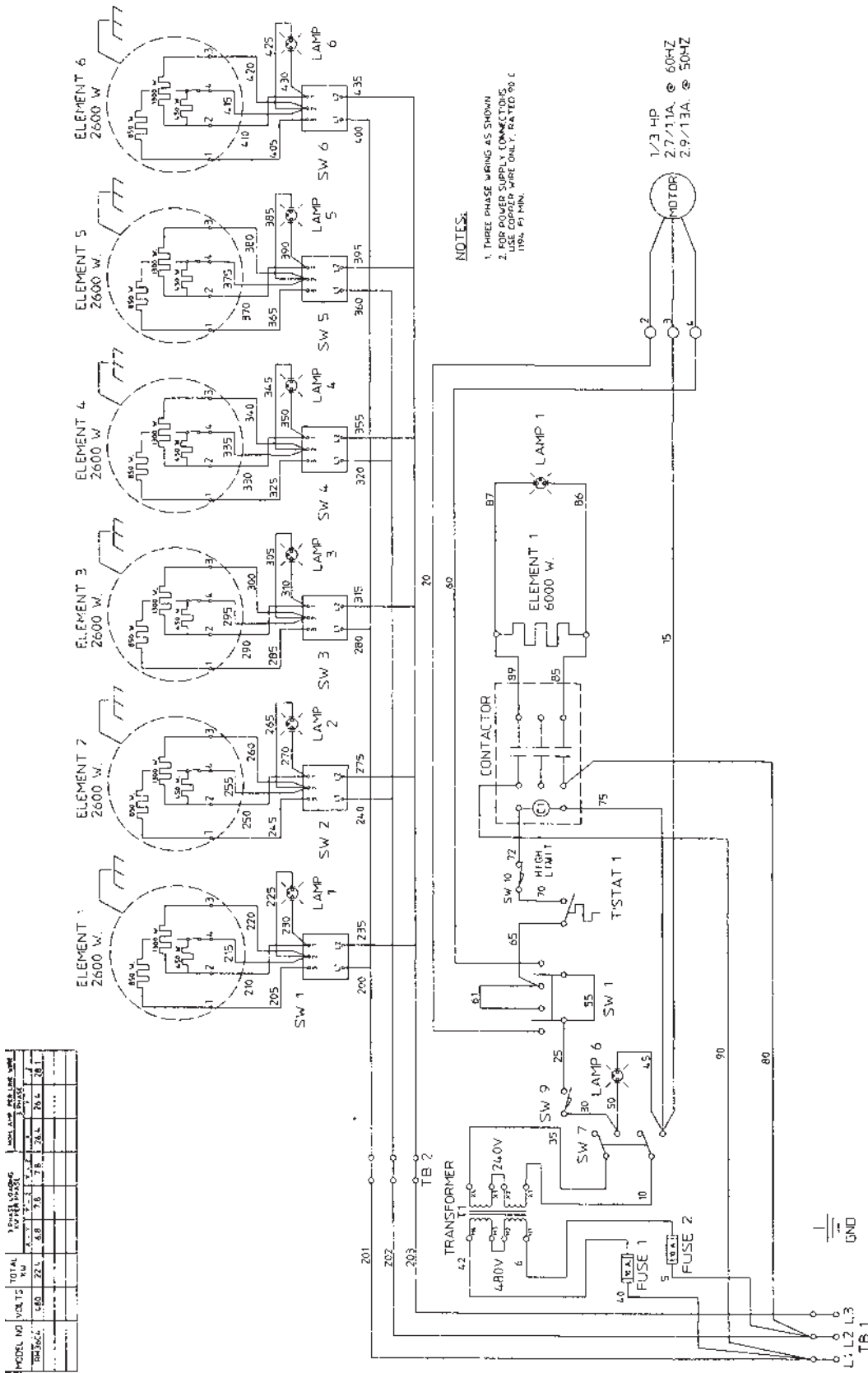

NOTES:
 1. THREE PHASE WIRING AS SHOWN
 2. FOR POWER SUPPLY CONNECTIONS, USE COPPER WIRE ONLY, RA TED 90 C 18#-14 MIN.

**RH36C4 WIRING DIAGRAM
 480V**

MODEL NO	VOLTS	TOTAL KW	1 PHASE WIRING	3 PHASE WIRING	WIRE AMP PER LINE WIRE
RH36C4	480	22.4	4.8	7.8	26.4
			4.8	7.8	26.4
			4.8	7.8	26.4
			4.8	7.8	26.4



Section 5 - SCHEMATICS

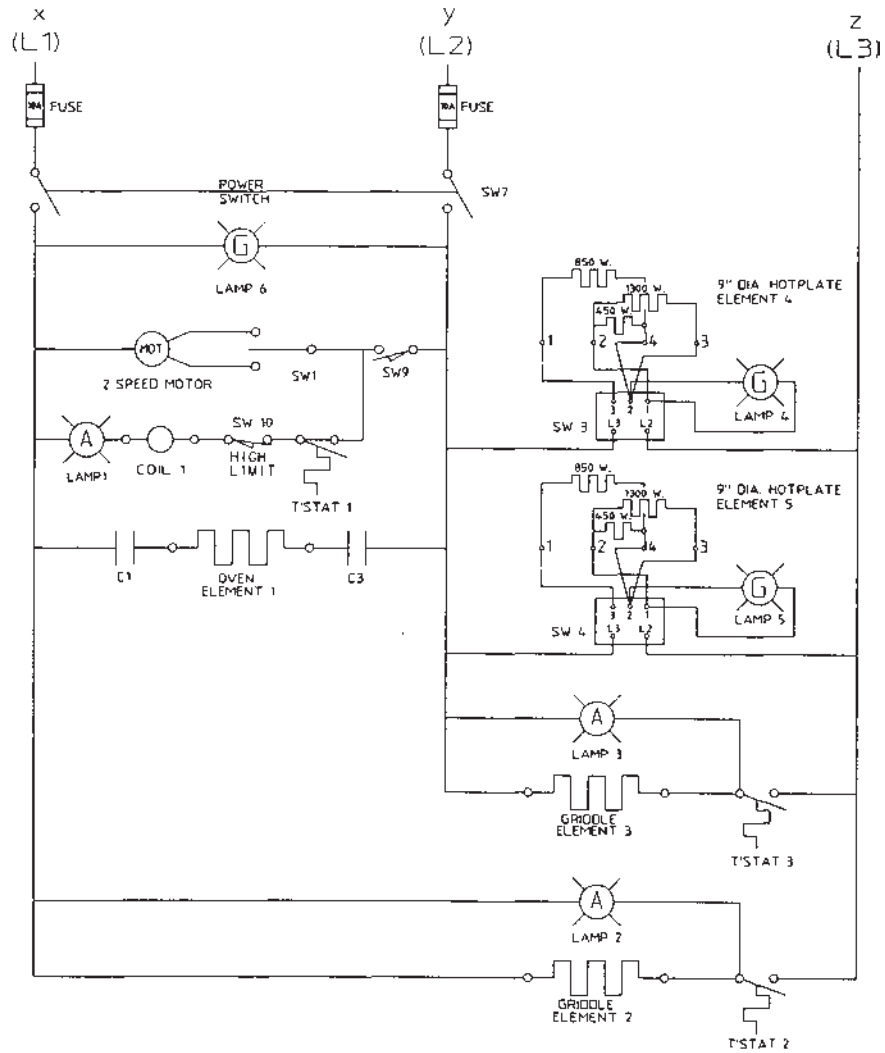

RH36C6 SCHEMATIC
208/240V

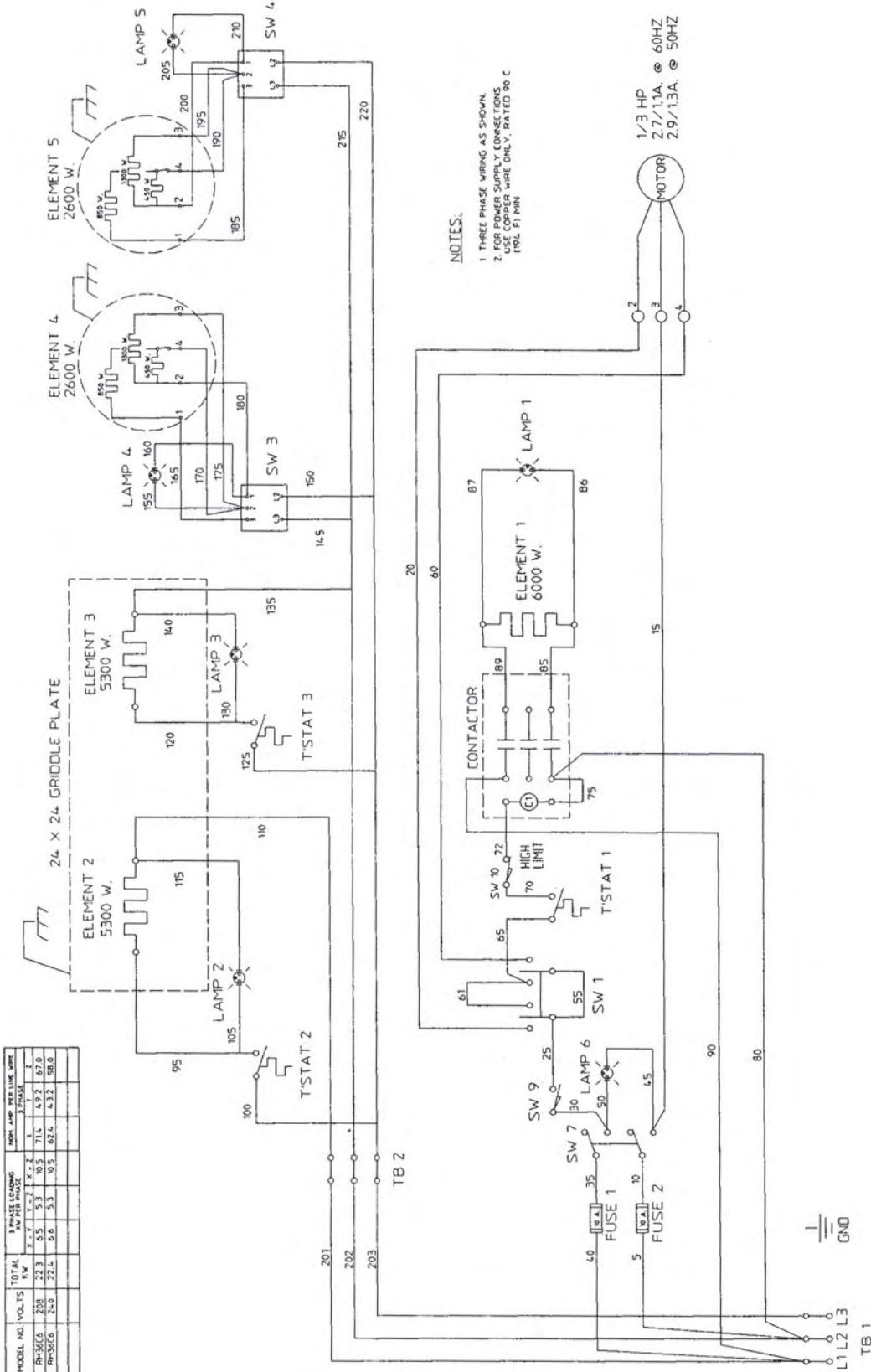

NOTES:
 1 THREE PHASE WIRING AS SHOWN.
 2 100% AMP PER LINE WIRE CONNECTIONS.
 3 194, F1 MIN. CAPACITANCE WIRE ONLY. RATED 90 C

**RH36C6 WIRING DIAGRAM
 208/240V**



Section 5 - SCHEMATICS

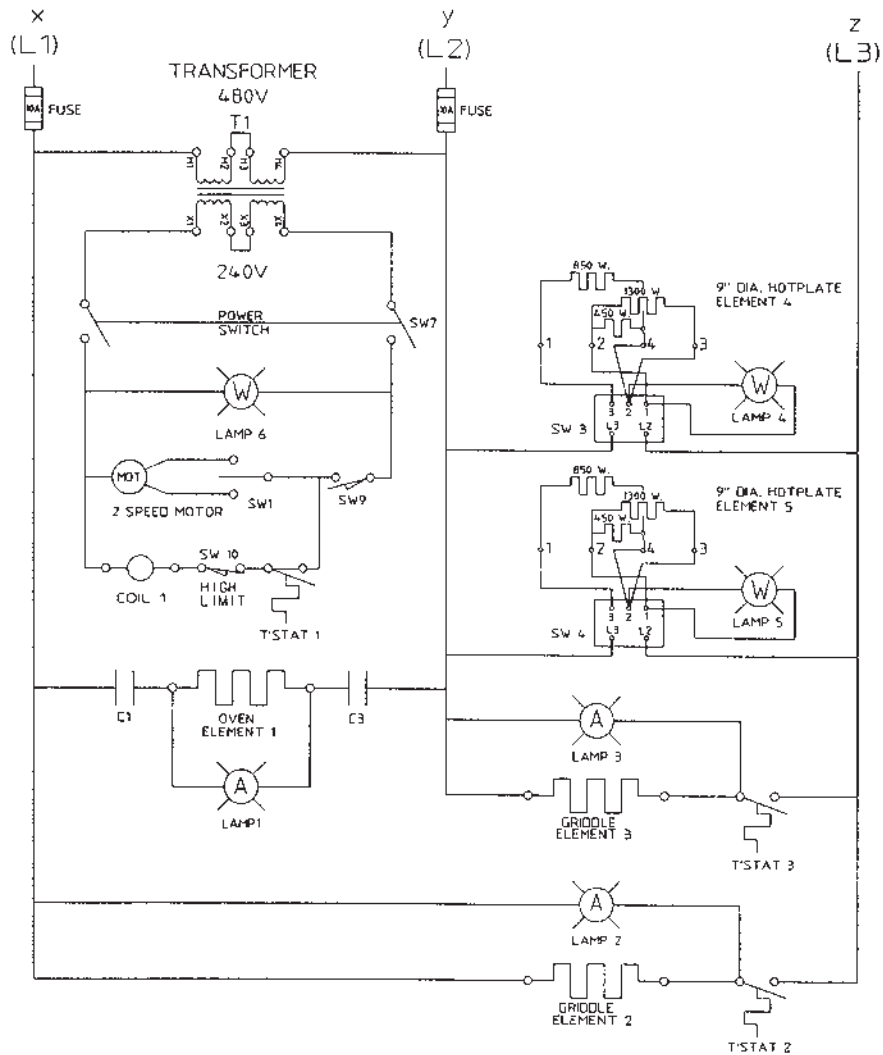

**RH36C6 SCHEMATIC
480V**

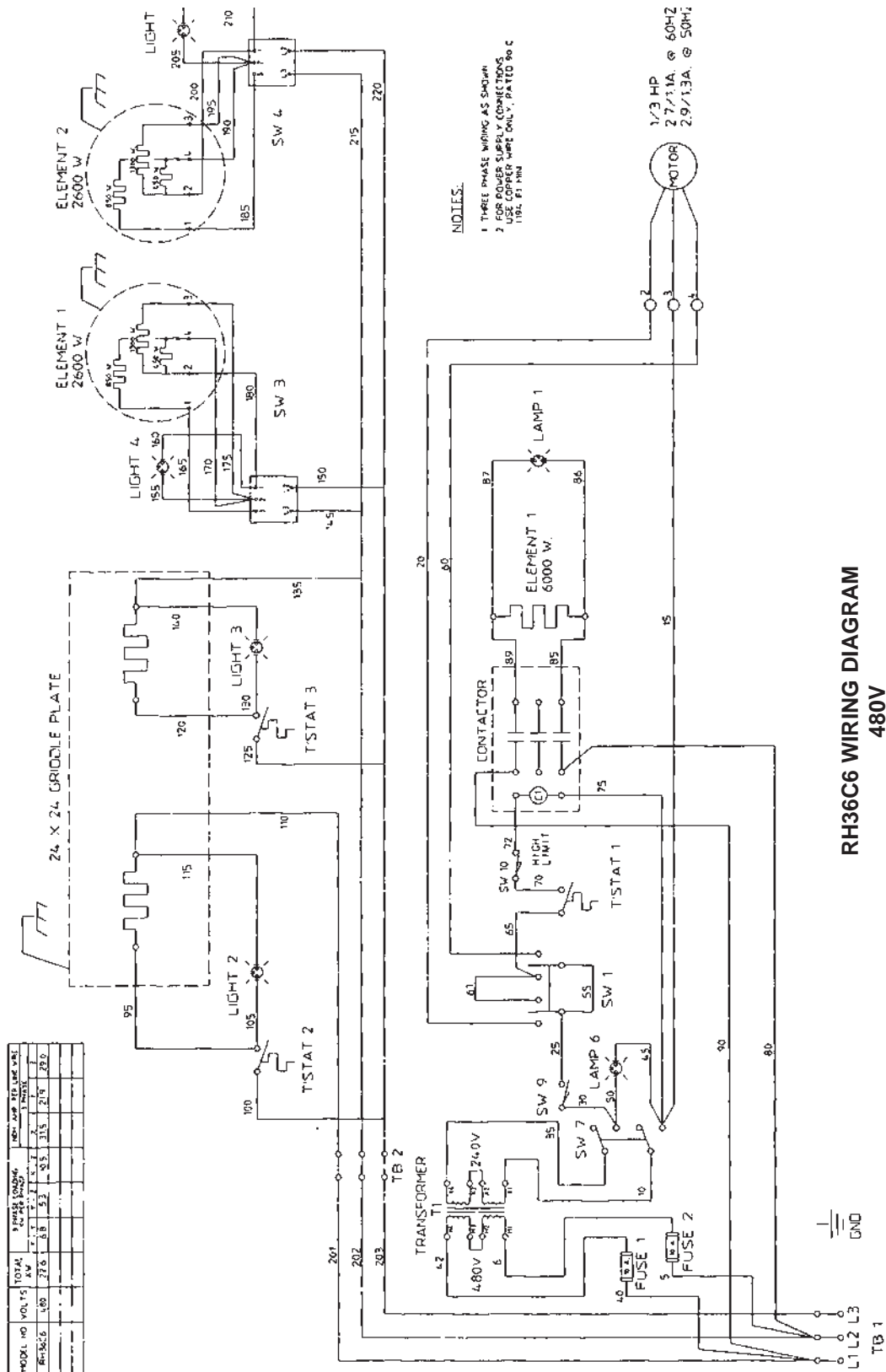

Section 5 - SCHEMATICS

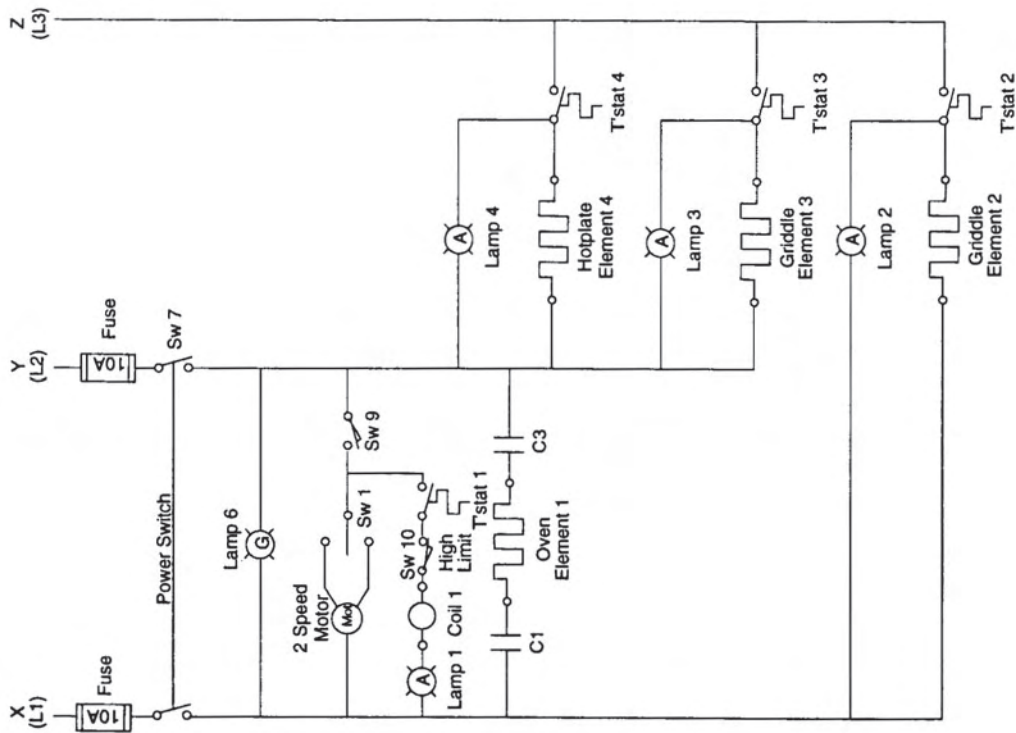

RH36C7 SCHEMATIC
208/240V

Model No.	Volts	Total kW	3 Phase Loading kW Per Phase			Nominal Amperes Per Line Wire 3 Phase		
			X-Y	Y-Z	X-Z	X	Y	Z
RH36C7	208	22.4	6.5	10.6	5.3	48.2	71.9	67.4
RH36C7	240	22.5	6.5	10.6	5.3	45.2	62.8	58.4

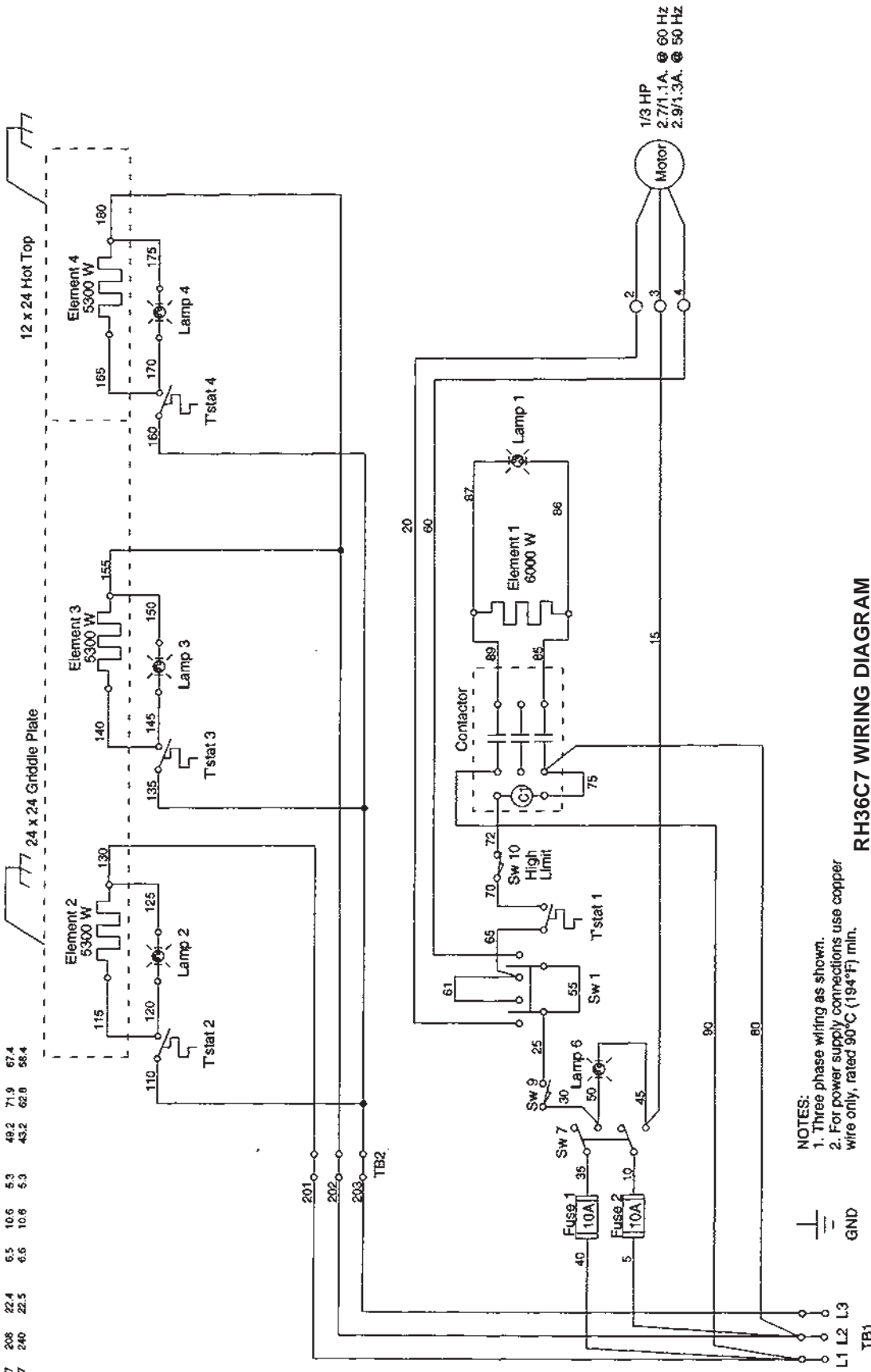

- NOTES:
1. Three phase wiring as shown.
 2. For power supply connections use copper wire only, rated 90°C (194°F) min.

RH36C7 WIRING DIAGRAM
208/240V



Section 5 - SCHEMATICS

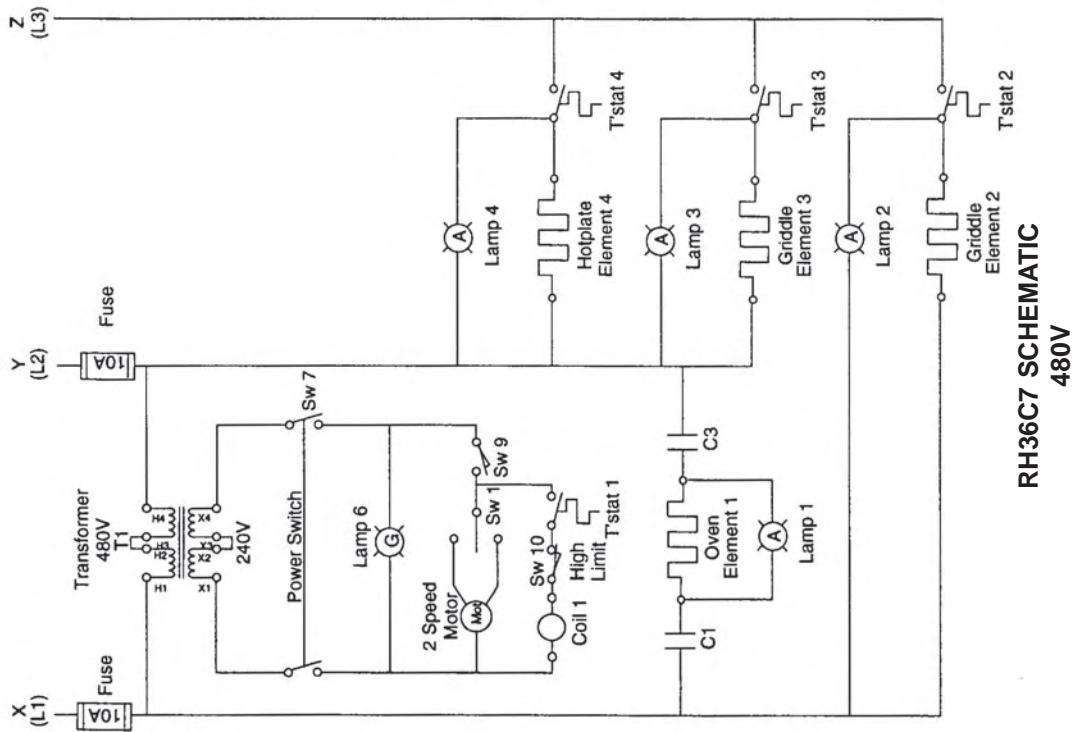

**RH36C7 SCHEMATIC
480V**

Model No.	Volts	Total kW	3 Phase Loading kW Per Phase			Nominal Amperes Per Line Wire 3 Phase		
			X-Y	Y-Z	X-Z	X	Y	Z
RH36C7	480	22.7	6.8	10.6	5.3	21.9	31.6	29.2

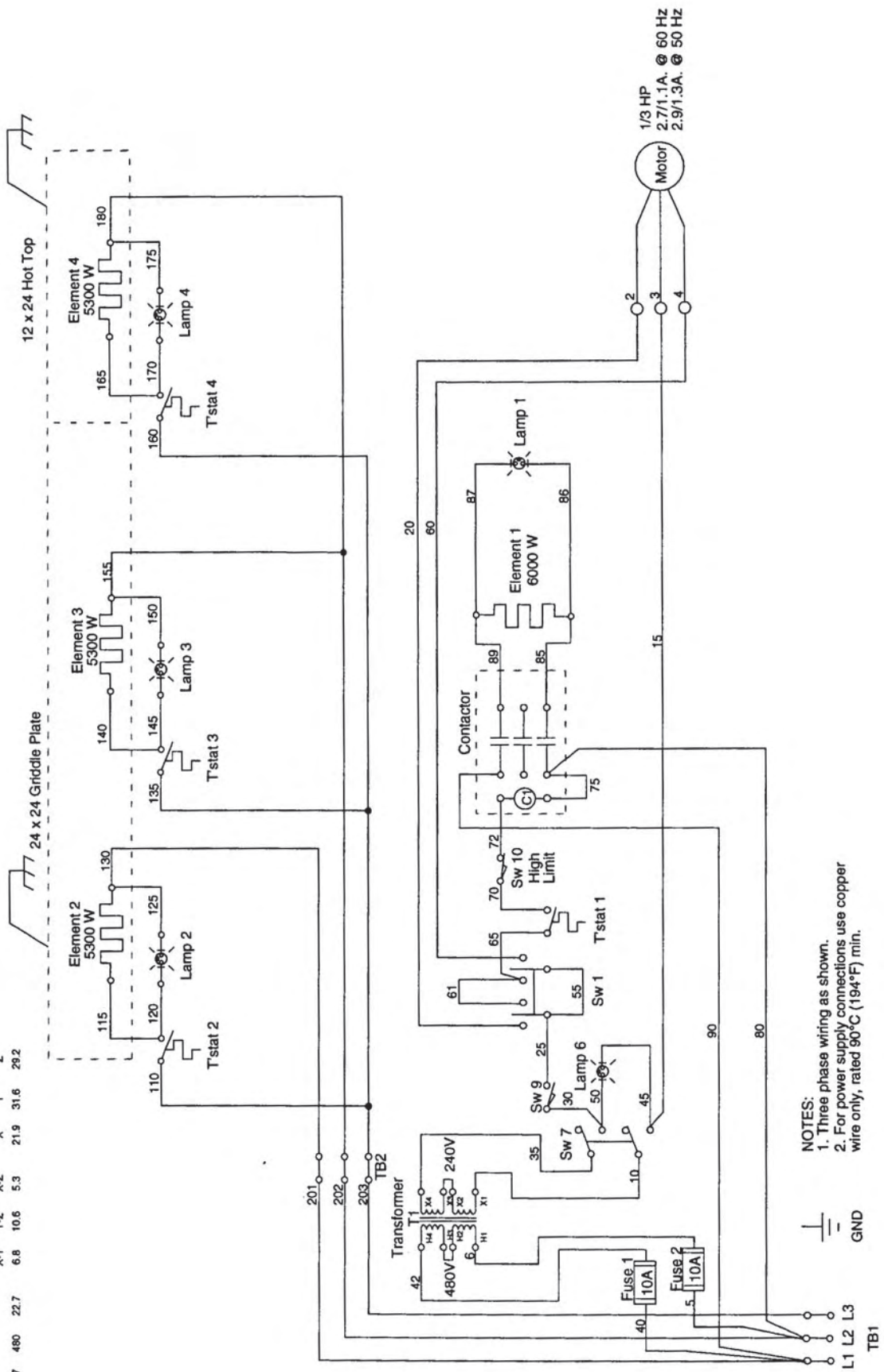

- NOTES:
1. Three phase wiring as shown.
 2. For power supply connections use copper wire only, rated 90°C (194°F) min.

RH36C7 WIRING DIAGRAM
480V

Section 5 - SCHEMATICS

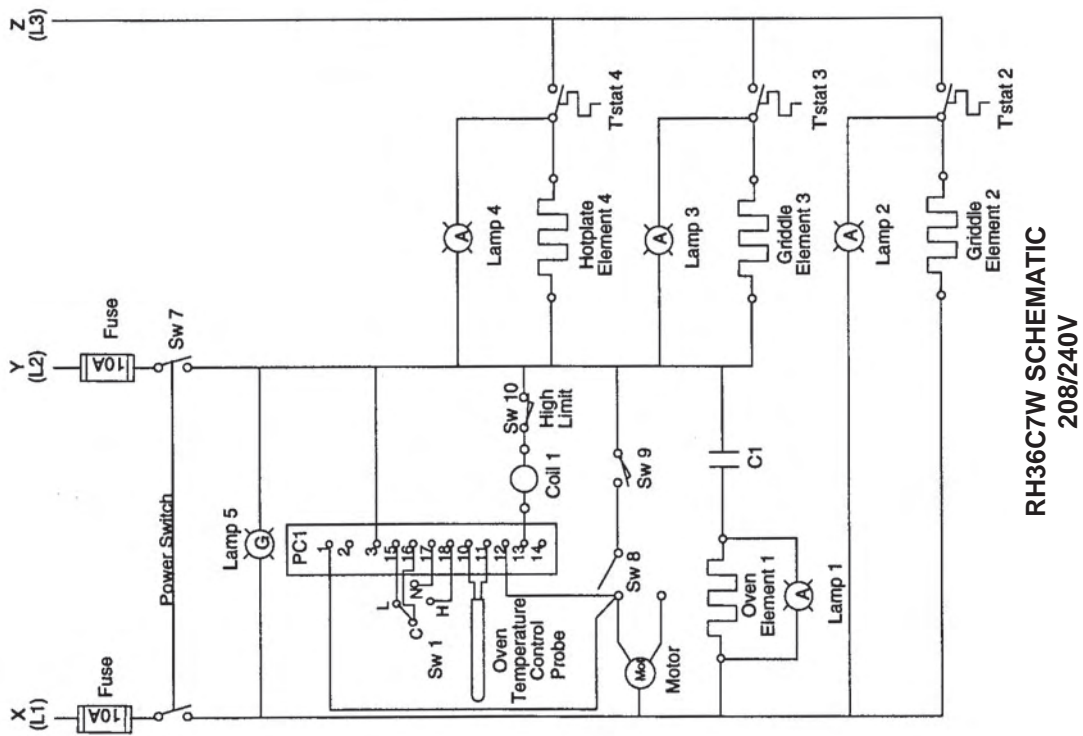

RH36C7W SCHEMATIC
208/240V

Model No.	Volts	Total kW	3 Phase Loading kW Per Phase			Nominal Amperes Per Line Wire 3 Phase		
			X-Y	Y-Z	X-Z	X	Y	Z
RH36C7	208	22.4	6.5	10.6	5.3	49.2	71.9	67.4
RH36C7	240	22.5	6.6	10.6	5.3	43.2	62.8	58.4

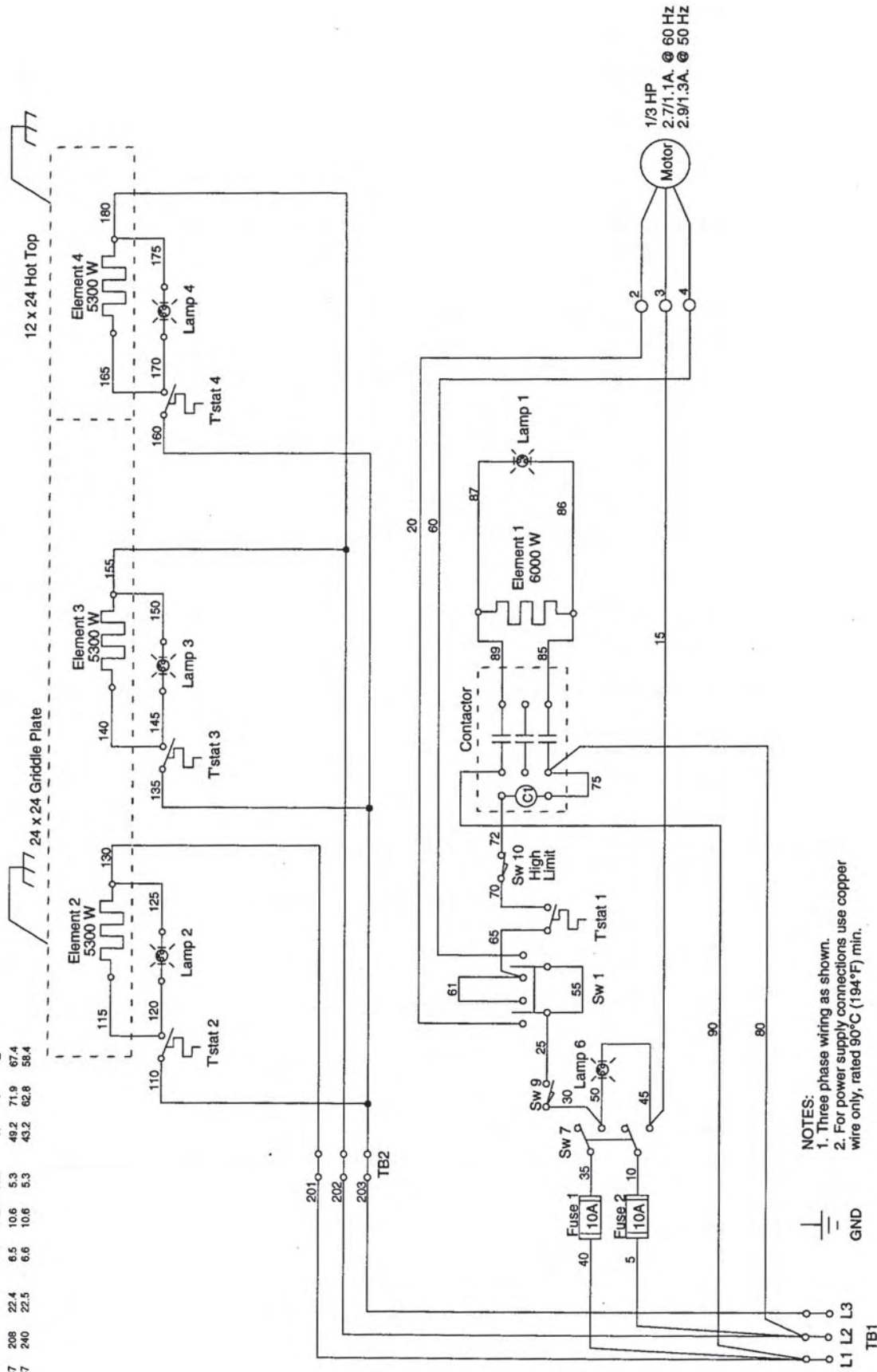

- NOTES:
1. Three phase wiring as shown.
 2. For power supply connections use copper wire only, rated 90°C (194°F) min.

GND

**RH36C7W WIRING DIAGRAM
208/240V**

Section 5 - SCHEMATICS

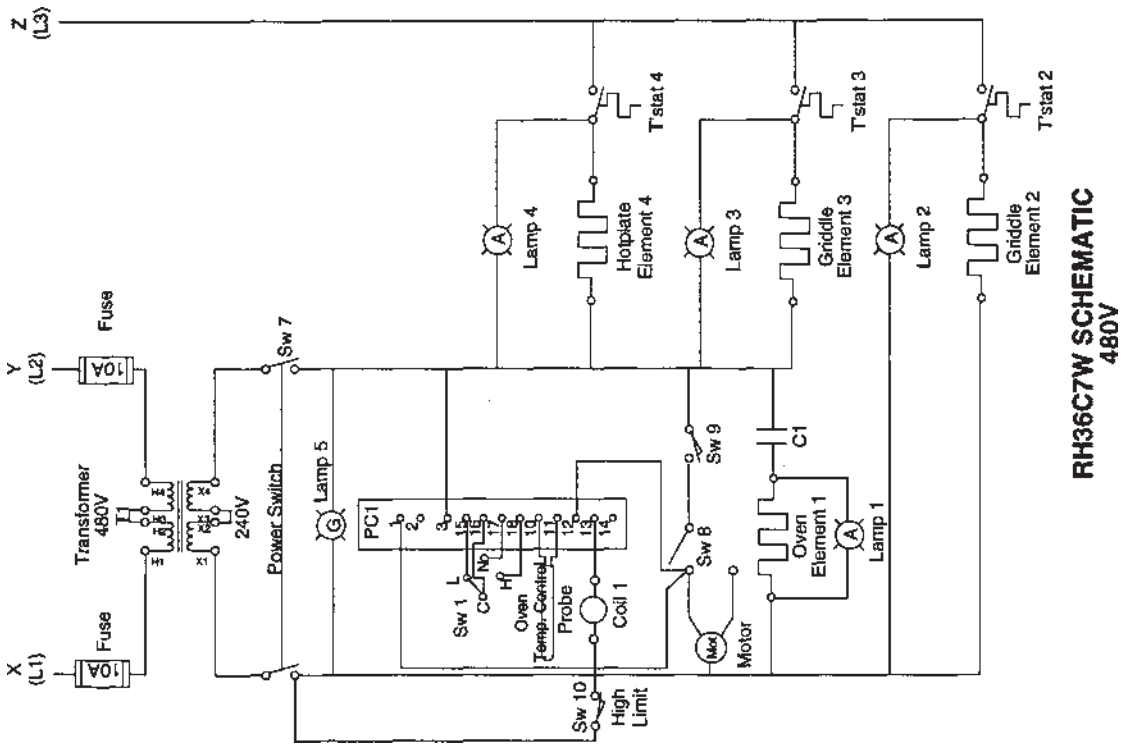

**RH36C7W SCHEMATIC
480V**

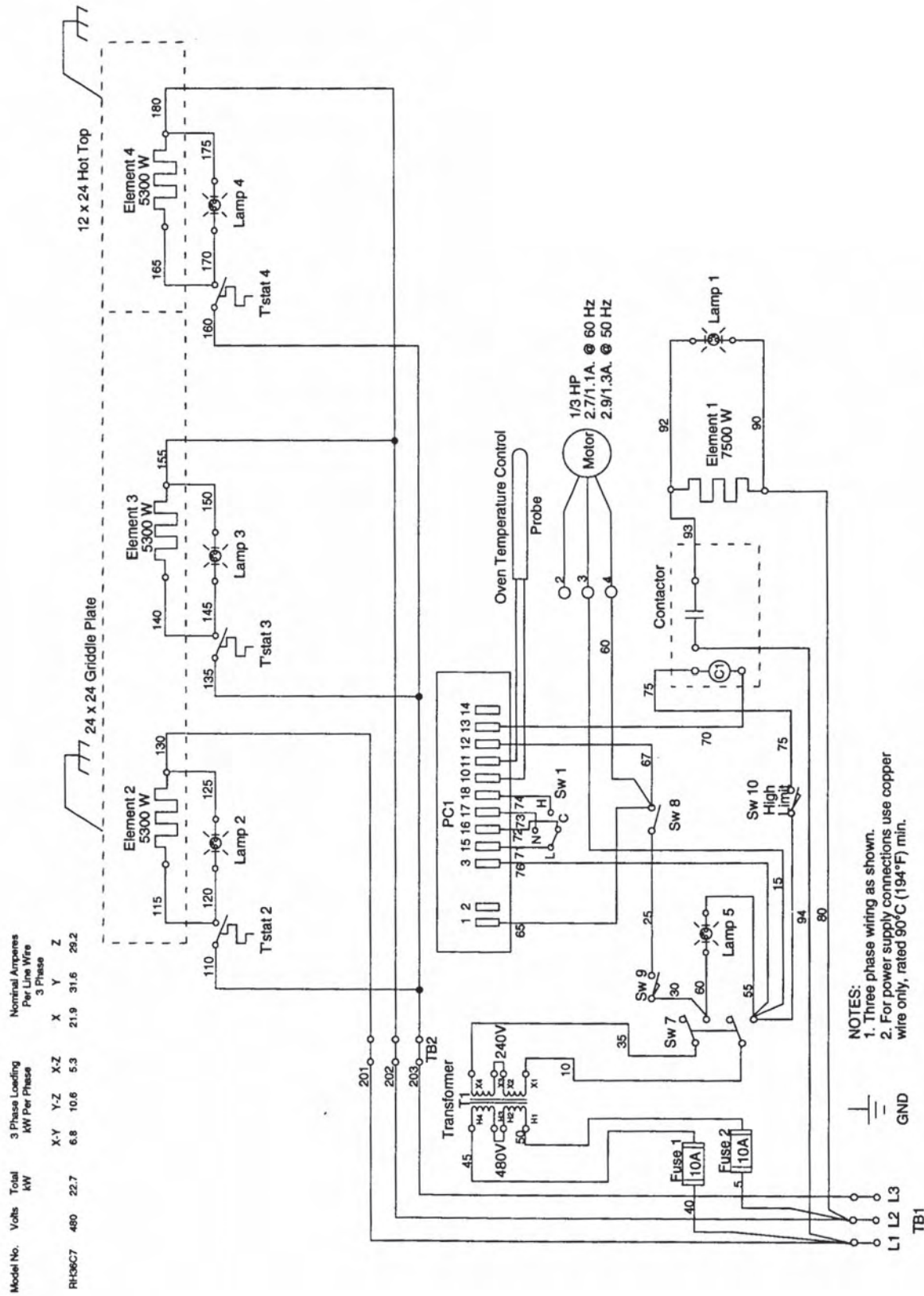

RH36C7W WIRING DIAGRAM
480V

NOTES:
1. Three phase wiring as shown.
2. For power supply connections use copper wire only, rated 90°C (194°F) min.

GND

This page intentionally left blank

STAR INTERNATIONAL HOLDINGS INC. COMPANY
Star - Holman - Lang - Wells - Bloomfield - Toastmaster
10 Sunnen Drive, St. Louis, MO 63143 U.S.A.
(800) 807-9054 (314) 781-2777
Parts & Service (800) 807-9054
www.star-mfg.com